

CHECK VALVE

CDVN-XXX-PANS

MONODIRECTIONAL
POPPET TYPE

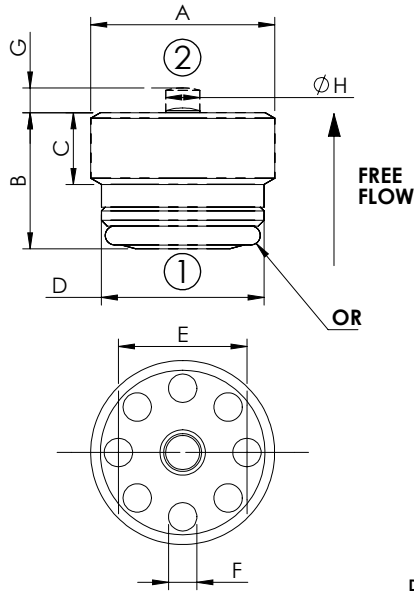

SPECIFICATIONS

Max. operating pressure:	500 bar (7200 psi)
Weight:	3.0 - 45 g(0,01 - 0,1 lbs)
Contamination class to ISO 4406:	See technical spec.
MTF _a :	150 - 1200 years: See technical spec.

NOTES

Hardened seat and piston
For other configurations/quick codes not available in this catalogue page please consult factory

SPECIFICATIONS

Quick code	A	B	C	D	E	F	G	H	OR
CD000173	G 1/8"	7,2 [0,28]	3,8 [0,15]	8,6 [0,34]	6,8 [0,27]	1,5 [0,06]	1,3 [0,05]	1,8 [0,07]	6,00 x 1 N90 [0,236x0,039]
CD000174	G 1/4"	9 [0,32]	4,5 [0,18]	11,5 [0,45]	8,8 [0,35]	2,2 [0,09]	1,5 [0,06]	2,4 [0,09]	9,00 x 1 N90 [0,354x0,039]
CD000175	G 3/8"	11,2 [0,44]	6,5 [0,26]	15 [0,59]	11 [0,43]	3 [0,12]	2,5 [0,1]	3,2 [0,13]	11,00 x 1,5 N90 [0,433x0,059]
CD000176	G 1/2"	13,5 [0,53]	8 [0,32]	18,5 [0,73]	14,2 [0,56]	3,8 [0,15]	3 [0,12]	4 [0,16]	14,00 x 1,5 N90 [0,551x0,059]
CD000178	G 3/4"	17,5 [0,69]	10 [0,39]	24 [0,95]	18,5 [0,73]	4,6 [0,18]	3,5 [0,14]	5,5 [0,22]	18,77 x 1,78 N90 [0,739x0,070]

CURVES

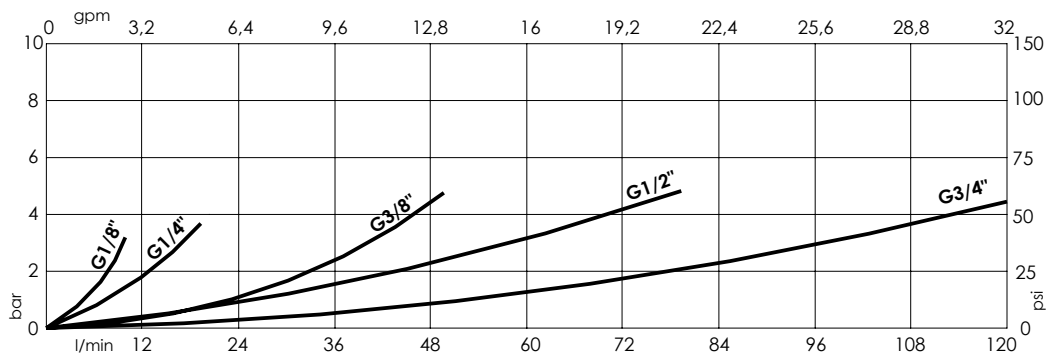

ORDERING CODES

Quick code	Description	Cracking pressure	Rated flow	Cavity	Installation torque	Installation tool
CD000173	CDVN-010-PANS-307-N000	0,1 bar (1,5 psi)	10 l/min (3 gpm)	VP000307 (G1/8")	8 Nm (6 ft-lb)	UM000390
CD000174	CDVN-020-PANS-309-N000	0,2 bar (3 psi)	20 l/min (5 gpm)	VP000309 (G1/4")	15 Nm (11 ft-lb)	UM000391
CD000175	CDVN-050-PANS-310-N000	0,2 bar (3 psi)	50 l/min (13 gpm)	VP000310 (G3/8")	20 Nm (15 ft-lb)	UM000392
CD000176	CDVN-080-PANS-311-N000	0,2 bar (3 psi)	80 l/min (21 gpm)	VP000311 (G1/2")	40 Nm (30 ft-lb)	UM000393
CD000178	CDVN-120-PANS-312-N000	0,1 bar (1,5 psi)	120 l/min (32 gpm)	VP000312 (G3/4")	80 Nm (59 ft-lb)	UM000394