

# CDPN-030-PANR

INTEGRAL PILOT  
PISTON

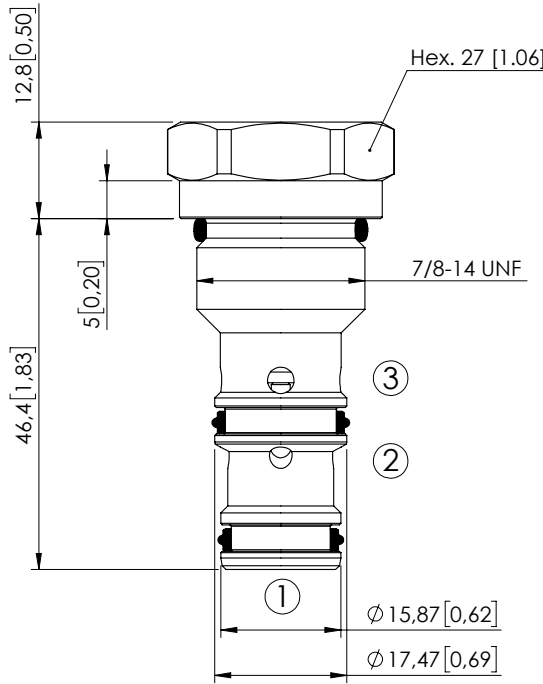

Dimensions: mm [inches]

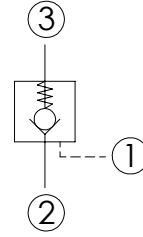

## SPECIFICATIONS

Max. operating pressure:	350 bar (5000 psi)
Rated flow:	30 l/min (8 gpm)
Cavity:	SAE-10-3N
Weight:	0,13 kg (0,28 lbs)
Pilot ratio:	4:1
Contamination class to ISO 4406:	See technical spec.
Seal kit:	RB600092
Installation torque:	55 - 62 Nm (41 - 46 ft-lb)
MTF <sub>a</sub> :	150 years

## NOTES

For other configurations/quick codes not available in this catalogue page please consult factory

## CURVES

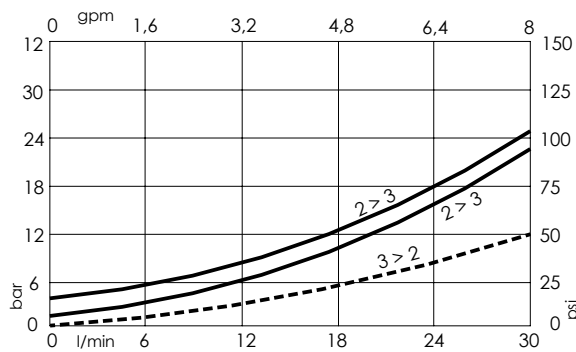

## ORDERING CODES

Quick code	Description	Cracking pressure	O-ring on pilot piston
CD000631	CDPN-030-PANR-04-S10-N002	2 bar (30 psi)	YES
CD000632	CDPN-030-PANR-04-S10-N004	4 bar (60 psi)	YES