

CPLV-080-DHNA

DIRECT ACTING
STABILIZED PISTON
CHAMBER VENTED

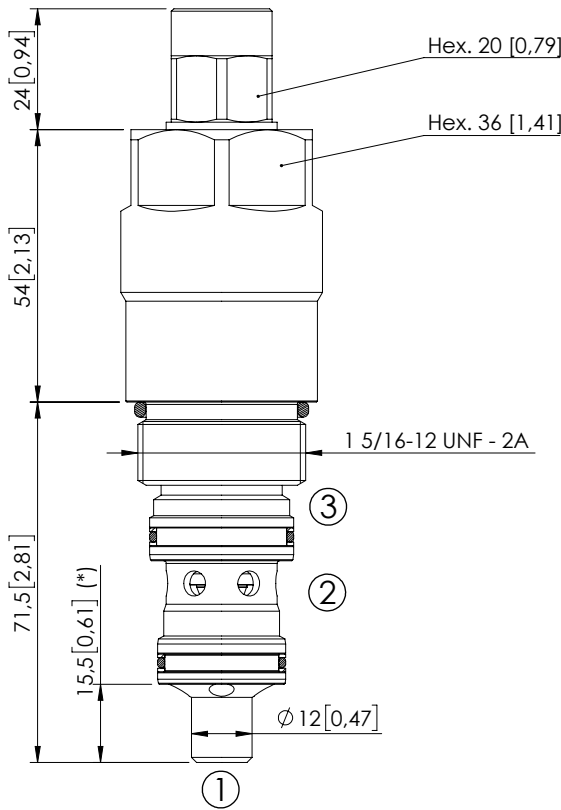

Dimensions: mm [inches]

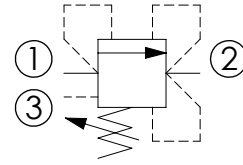

SPECIFICATIONS

Max. operating pressure:	350 bar (5000 psi)
Rated flow:	80 l/min (21 gpm)
Cavity:	SAE-16-3C
Weight:	0,75 kg (1,65 lbs)
Contamination class to ISO 4406:	See technical spec.
Seal kit:	RB100089
Installation torque:	118 - 132 Nm (87 - 97 ft-lb)
MTF _d :	150 - 1200 years: See technical spec.

NOTES

(*) The cartridge exceed overall dimension of the standard cavity into port 1.

For other configurations/quick codes not available in this catalogue page please consult factory

CURVES

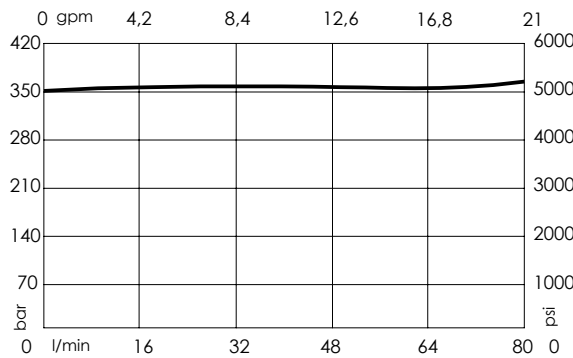

ORDERING CODES

Quick code	Description	Standard setting (cracking pressure)	Adjustment range	Pressure increase
CP000171	CPLV-080-DHNA-HN-S16-V420	400 bar (5700 psi)	150-420 bar (2100-6000 psi)	53 bar/turn (750 psi/turn)
CP000513	CPLV-080-DHNA-HN-S16-V350	350 bar (5000 psi)	100-350 bar (1400-5000 psi)	42 bar/turn (600 psi/turn)
CP000501	CPLV-080-DHNA-HN-S16-V200	200 bar (2900 psi)	60-210 bar (900-3000 psi)	24 bar/turn (350 psi/turn)
CP000514	CPLV-080-DHNA-HN-S16-V100	100 bar (1400 psi)	25-100 bar (400-1400 psi)	13 bar/turn (200 psi/turn)
CP000515	CPLV-080-DHNA-HN-S16-V050	50 bar (700 psi)	5-50 bar (100-700 psi)	9 bar/turn (150 psi/turn)