

Mounting example

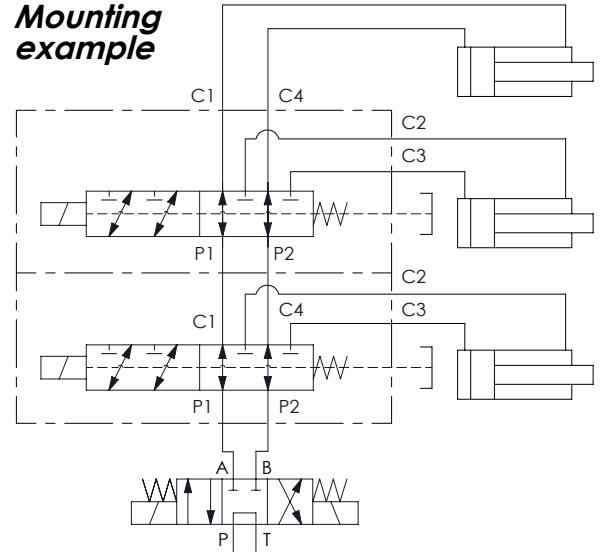

Technical data			
Rated flow		l/min (gpm)	100 (26)
Operating pressure	with internal drain "N"	bar (psi)	250 (3600)
	with external drain "E"	bar (psi)	350 (5000)
	on port D	bar (psi)	210 (2900)
Valve weight		Kg (lb)	3,8 (8,3)

OVERALL DIMENSIONS

Dimensions: mm [inches]

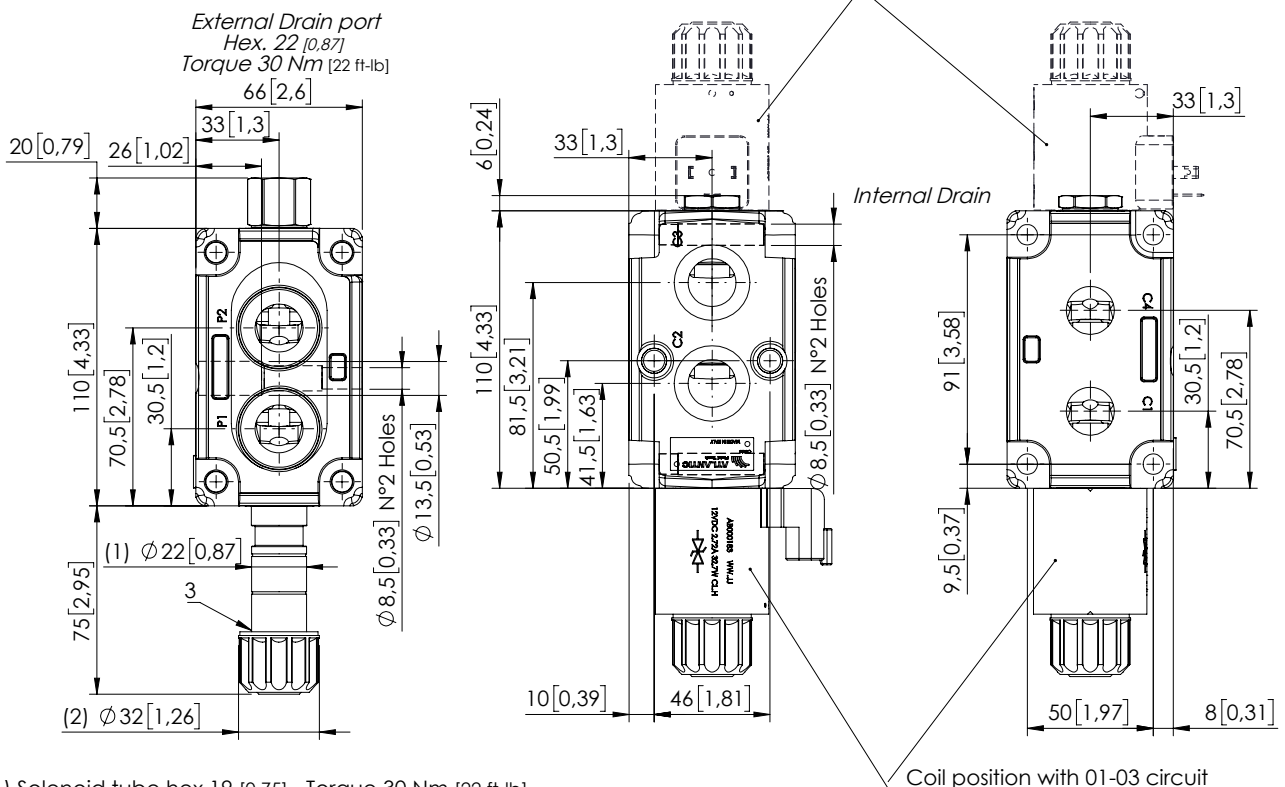

- (1) Solenoid tube hex.19 [0,75] - Torque 30 Nm [22 ft-lb]
- (2) Ring nut for coil locking - Torque 5-6 Nm [4-5 ft-lb]
- (3) O-Ring Ø 21,5x2 [0,85x0,08]

Characteristic curves

Measured with hydraulic fluid ISO-VG46 at 40°±5°C (104°F±41°F)

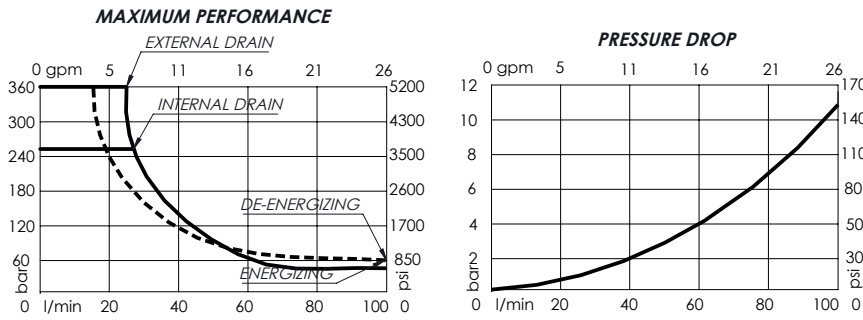

Internal leakage on C ports:
MAX 25 cm³/min (1.5 in³/min)
 Mineral oil with 32 cSt viscosity,
 at 40° C (104° F) and
 100 bar (1400 psi) pressure.

*	OPERATED	<i>Circuit</i>	*	MANUAL OVERRIDE	*	DRAIN	<i>Circuit</i>															
E	Electric 		S	Standard 	N	Internal 																
N	Hydraulic/pneumatic 		V	Screw 	E	External 																
			N	Without manual override (Only for hydraulic version)	<table border="1"> <thead> <tr> <th colspan="3">PORTS</th> </tr> <tr> <th>***</th> <th>Main (C)</th> <th>Drain (D)</th> </tr> </thead> <tbody> <tr> <td>G12</td> <td>1/2" Gas</td> <td>1/4" Gas</td> </tr> <tr> <td>J12</td> <td>1/2" JIS</td> <td>1/4" JIS</td> </tr> <tr> <td>S10</td> <td>7/8-14 UNF</td> <td>7/16-20 UNF</td> </tr> </tbody> </table> <p>Other port sizes available</p>			PORTS			***	Main (C)	Drain (D)	G12	1/2" Gas	1/4" Gas	J12	1/2" JIS	1/4" JIS	S10	7/8-14 UNF	7/16-20 UNF
PORTS																						
***	Main (C)	Drain (D)																				
G12	1/2" Gas	1/4" Gas																				
J12	1/2" JIS	1/4" JIS																				
S10	7/8-14 UNF	7/16-20 UNF																				
					<p>N - Seals in NBR V - Seals in VITON</p>																	

ESFB - 100 - * * D * - ** - * - * ** * ****

*	Voltage (V)	Resistance (Ω) ± 7%	Power (W)	Current (A)
-	Without coil			
A	12 DC	4,41	32,7	2,72
B	24 DC	18,6	31	1,29

Other voltages available on request

*	COIL	Type	Protection class
-	Without coil		
HR	DIN 43650 - ISO 4400 Class H	M12	IP65
AJ	AMP JUNIOR Class H	M12	IP65
DT	DEUTSCH DT04-2P-L Class H	M12	IP69

TYPE OF MOUNTING

*	Port number	Screw Tie rods	Installation torque
-	6	-	-
08	8	M8x125 [M8x5,2]	15-17 Nm [11-13 ft-lb]
10	10	M8x190 [M8x7,8]	15-17 Nm [11-13 ft-lb]
12	12	M8x255 [M8x10,39]	15-17 Nm [11-13 ft-lb]
14	14	M8x320 [M8x12,99]	15-17 Nm [11-13 ft-lb]