

MRSN-150-ALBE

REGENERATIVE
WITH ELECTRIC BY-PASS

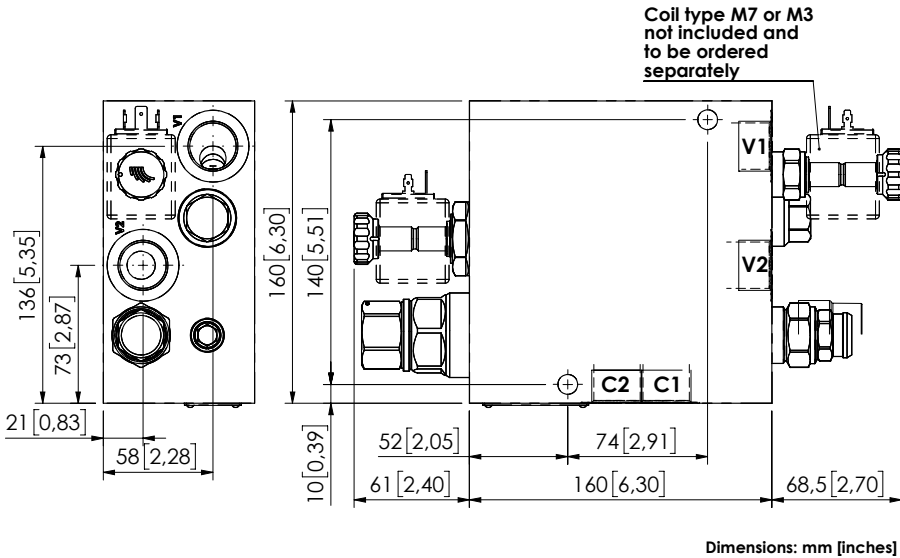
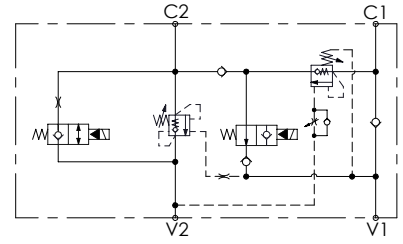
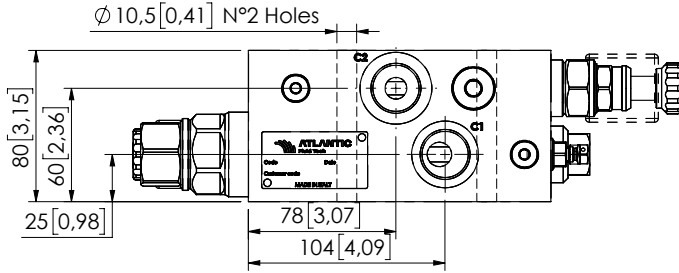

SPECIFICATIONS

Max. operating pressure:	350 bar (5000 psi)
Rated flow:	150 l/min (40 gpm)
Manifold:	Steel
Coil type:	M7 or M3 type
Weight:	14.95 kg (32.95 lbs)
Contamination class to ISO 4406:	See technical spec.
MTTFa:	150 - 1200 years: See technical spec.

NOTES

Setting: at least 1.3 times the load induced pressure.
For other configurations/quick codes not available in this catalogue page please consult factory

SEALING CAP



Ordering code:
ST000012

CURVES

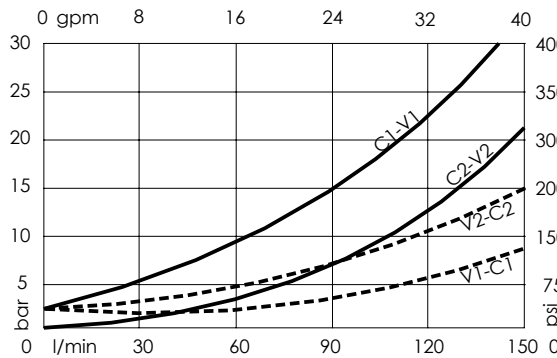

ORDERING CODES

Quick code	Description	Pilot ratio	Ports	Standard setting Q=5 l/min (1.3 gpm)	Adjustment range	Pressure increase
MB000920	MRSN-150-ALBE-04-G34-N350	4:1	V1,V2: G 3/4" C1,C2: G 3/4"	350 bar (5000 psi)	100-350 bar (1500-5000 psi)	104 bar/turn (1500 psi/turn)