



ATLANTIC
Fluid Tech

**SECTION
10**

Check and
Metering
Valves

CHECK AND METERING VALVES

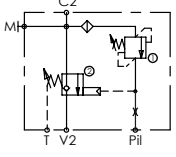
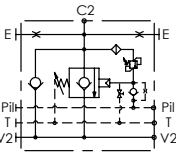
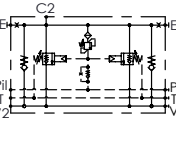
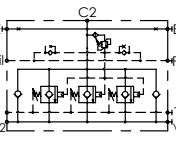
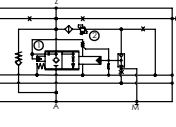
Hydraulic scheme	Valve description	Valve type	Rated flow l/min (gpm)	Max. pressure bar (psi)	Installation	Main port size or cavity type	Page
	MLST-040-ALGR	Right version	40 (11)	420 (6000)	In line	G 3/8"	10.01.010
	MLST-040-ALGL	Left version	40 (11)	420 (6000)	In line	G 3/8"	10.01.020
	MLST-100-ALGR	Right version	100 (26)	420 (6000)	In line	G 1/2"	10.01.030
	MLST-100-ALGL	Left version	100 (26)	420 (6000)	In line	G 1/2"	10.01.040
	MLST-150-ALGR	Right version	150 (40)	420 (6000)	In line	G 3/4"	10.01.050
	MLST-150-ALGL	Left version	150 (40)	420 (6000)	In line	G 3/4"	10.01.060
	MLLT-100-AAGN	Right and left version	100 (26)	420 (6000)	Flanged	1/2" SAE 6000	10.02.070
	MLLT-150-AAGN	Right and left version	150 (40)	420 (6000)	Flanged	1/2" SAE 6000	10.02.080
	MLLT-200-AAGR	Right and left version	250 (66)	420 (6000)	Flanged	3/4" SAE 6000	10.02.090
	MLLT-200-AAGR	Right and left version	250 (66)	420 (6000)	Flanged	1" SAE 6000	10.02.100
	MLLT-300-AAGR	Right and left version	350 (93)	420 (6000)	Flanged	3/4" SAE 6000	10.02.110
	MLLT-300-AAGN	Right and left version	400 (106)	420 (6000)	Flanged	1" SAE 6000	10.02.120
	MLLT-500-AAJN	Right and left version	500 (132)	420 (6000)	Flanged	3/4" SAE 6000	10.03.140
	MLLT-500-AAGN	Right and left version	500 (132)	420 (6000)	Flanged	1" SAE 6000	10.03.150
	MLLT-550-AAGN	Right and left version	550 (146)	420 (6000)	Flanged	1 1/4" SAE 6000	10.03.160
	MLLT-700-AAGN	Right and left version	700 (185)	420 (6000)	Flanged	1 1/4" SAE 6000	10.03.170
	MLLT-700-AAGN	Right and left version	700 (185)	420 (6000)	Flanged	1 1/2" SAE 6000	10.03.180
	MLLT-1400-AAGN	Right and left version	1400 (370)	420 (6000)	Flanged	1 1/2" SAE 6000	10.04.190
	MLLT-1400-AAGR	Right version	1400 (370)	420 (6000)	Flanged	2" SAE 6000	10.04.200
	MLLT-1400-AAGL	Left version	1400 (370)	420 (6000)	Flanged	2" SAE 6000	10.04.210
	MLLT-1500-AAGR	Right version	1500 (396)	420 (6000)	Flanged	2" SAE 6000 3" SAE 6000	10.04.220
	MLLT-1500-AAGL	Left version	1500 (396)	420 (6000)	Flanged	2" SAE 6000 3" SAE 6000	10.04.230
	MLNT-250-AAGN	Right and left version	250 (66)	420 (6000)	Flanged	3/4" SAE 6000	10.05.240
	MLNT-350-AAGN	Right and left version	350 (93)	420 (6000)	Flanged	1" SAE 6000	10.05.250
	MLNT-500-AAGN	Right and left version	500 (132)	420 (6000)	Flanged	1 1/4" SAE 6000	10.05.260

CHECK AND METERING VALVE

MLST-040-ALGR

IN LINE VERSION
RIGHT VERSION

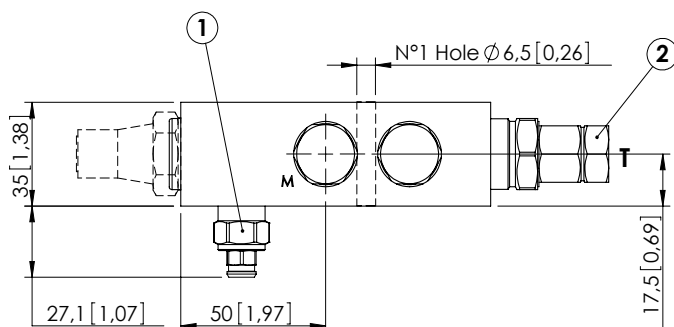
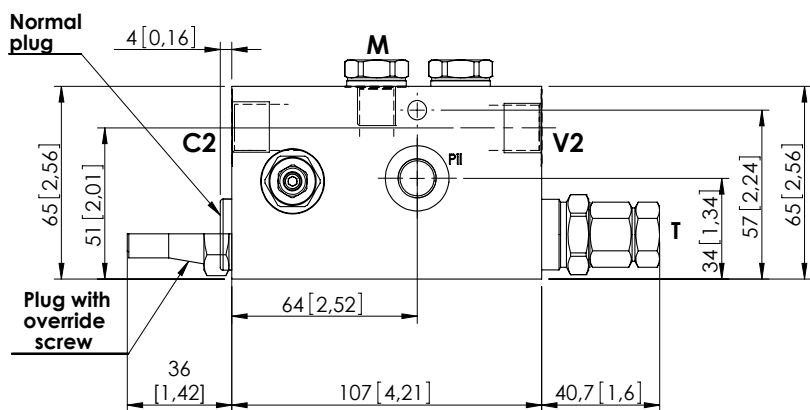

Dimensions: mm [inches]

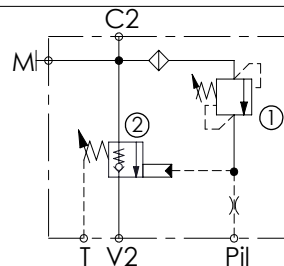

SPECIFICATIONS

Max. operating pressure:	420 bar (6000 psi)
Rated flow:	40 l/min (11 gpm)
Manifold:	Steel
Weight:	1,86 kg (4,1 lbs)
Contamination class to ISO 4406:	See technical spec.
MITF:	150 - 1200 years: See technical spec.

OPTIONS

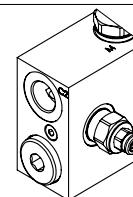
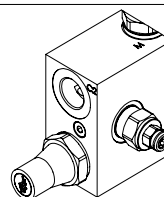

Plug with override screw

Normal plug

NOTES

When correctly adjusted for the specific excavator installation, these valves meet the requirement of ISO 8643.
For other configurations/quick codes not available in this catalogue page please consult factory

CURVES

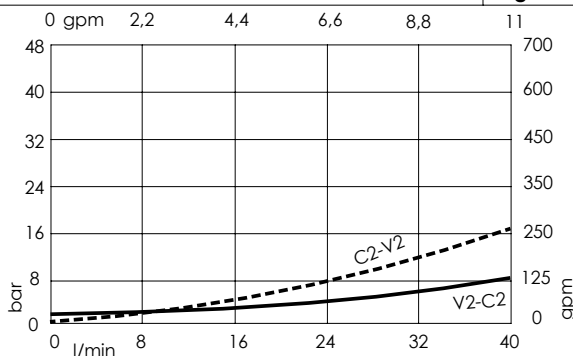

ORDERING CODES

Quick code	Description	Main ports size	Plug with override screw	Standard setting	Adjustment range	Pressure increase
ML000143	MLST-040-ALGR-00-G38-N420	V2,C2: G 3/8" Pii,T,M: G 1/4"	No	① 350 bar @5 l/min (5000 psi @1,3 gpm) ② 7.5 bar (100 psi) Crack. pr.	① 150-420 bar (2100-6000 psi) ② 3-15 bar (50-200 psi)	① 236 bar/turn (3400 psi/turn) ② 6.7 bar/turn (100 psi/turn)
ML000144	MLST-040-ALGR-00-G38-E420	V2,C2: G 3/8" Pii,T,M: G 1/4"	Yes	① 350 bar @5 l/min (5000 psi @1,3 gpm) ② 7.5 bar (100 psi) Crack. pr.	① 150-420 bar (2100-6000 psi) ② 3-15 bar (50-200 psi)	① 236 bar/turn (3400 psi/turn) ② 6.7 bar/turn (100 psi/turn)
ML000185	MLST-040-ALJR-00-J38-N420	V2,C2: JIS 3/8" Pii,T,M: JIS 1/4"	No	① 350 bar @5 l/min (5000 psi @1,3 gpm) ② 7.5 bar (100 psi) Crack. pr.	① 150-420 bar (2100-6000 psi) ② 3-15 bar (50-200 psi)	① 236 bar/turn (3400 psi/turn) ② 6.7 bar/turn (100 psi/turn)
ML000186	MLST-040-ALJR-00-J38-E420	V2,C2: JIS 3/8" Pii,T,M: JIS 1/4"	Yes	① 350 bar @5 l/min (5000 psi @1,3 gpm) ② 7.5 bar (100 psi) Crack. pr.	① 150-420 bar (2100-6000 psi) ② 3-15 bar (50-200 psi)	① 236 bar/turn (3400 psi/turn) ② 6.7 bar/turn (100 psi/turn)

CHECK AND METERING VALVE

MLST-040-ALGL

IN LINE VERSION
LEFT VERSION

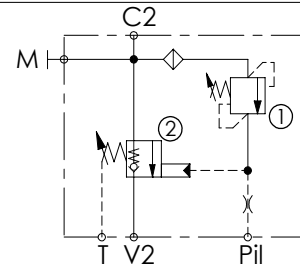
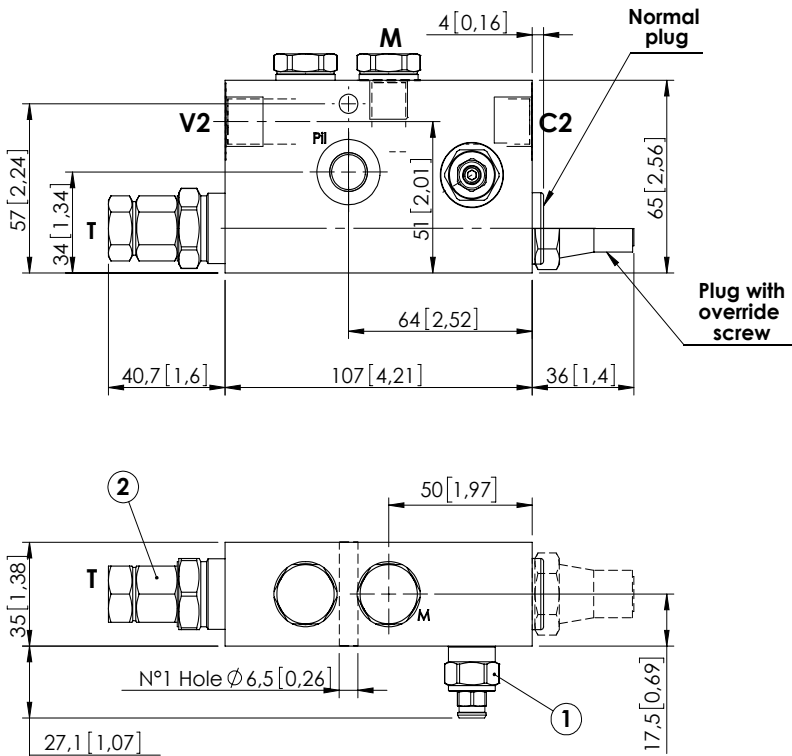

SPECIFICATIONS

Max. operating pressure:	420 bar (6000 psi)
Rated flow:	40 l/min (11 gpm)
Manifold:	Steel
Weight:	1,86 kg (4,1 lbs)
Contamination class to ISO 4406:	See technical spec.
MTTFd:	150 - 1200 years: See technical spec.

OPTIONS

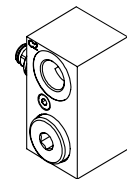
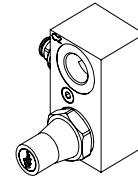

Plug with override screw

Normal plug

Dimensions: mm [inches]

NOTES

When correctly adjusted for the specific excavator installation, these valves meet the requirement of ISO 8643.
For other configurations/quick codes not available in this catalogue page please consult factory

CURVES

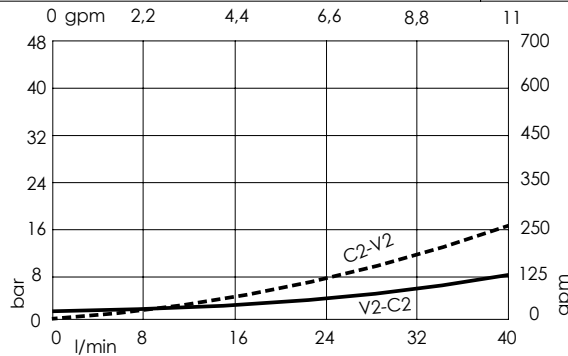

ORDERING CODES

Quick code	Description	Main ports size	Plug with override screw	Standard setting	Adjustment range	Pressure increase
ML000145	MLST-040-ALGL-00-G38-N420	V2,C2: G 3/8" P1,T,M: G 1/4"	No	① 350 bar @5 l/min (5000 psi @1,3 gpm) ② 7.5 bar (100 psi) Crack. pr.	① 150-420 bar (2100-6000 psi) ② 3-15 bar (50-200 psi)	① 236 bar/turn (3400 psi/turn) ② 6.7 bar/turn (100 psi/turn)
ML000146	MLST-040-ALGL-00-G38-E420	V2,C2: G 3/8" P1,T,M: G 1/4"	Yes	① 350 bar @5 l/min (5000 psi @1,3 gpm) ② 7.5 bar (100 psi) Crack. pr.	① 150-420 bar (2100-6000 psi) ② 3-15 bar (50-200 psi)	① 236 bar/turn (3400 psi/turn) ② 6.7 bar/turn (100 psi/turn)
ML000187	MLST-040-ALJL-00-J38-N420	V2,C2: JIS 3/8" P1,T,M: JIS 1/4"	No	① 350 bar @5 l/min (5000 psi @1,3 gpm) ② 7.5 bar (100 psi) Crack. pr.	① 150-420 bar (2100-6000 psi) ② 3-15 bar (50-200 psi)	① 236 bar/turn (3400 psi/turn) ② 6.7 bar/turn (100 psi/turn)
ML000188	MLST-040-ALJL-00-J38-E420	V2,C2: JIS 3/8" P1,T,M: JIS 1/4"	Yes	① 350 bar @5 l/min (5000 psi @1,3 gpm) ② 7.5 bar (100 psi) Crack. pr.	① 150-420 bar (2100-6000 psi) ② 3-15 bar (50-200 psi)	① 236 bar/turn (3400 psi/turn) ② 6.7 bar/turn (100 psi/turn)

CHECK AND METERING VALVE

MLST-100-ALGR

IN LINE VERSION
RIGHT VERSION

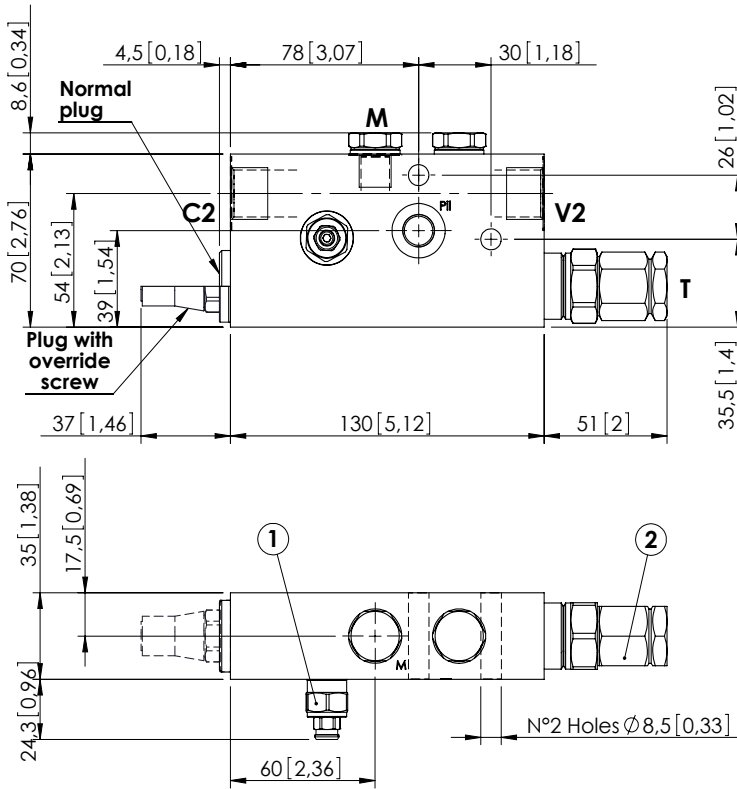

Dimensions: mm [inches]

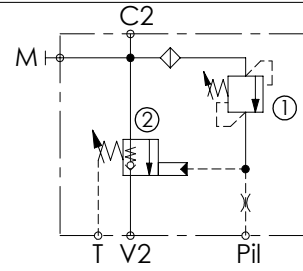

SPECIFICATIONS

Max. operating pressure:	420 bar (6000 psi)
Rated flow:	100 l/min (26 gpm)
Manifold:	Steel
Weight:	2,41 kg (5,27 lbs)
Contamination class to ISO 4406:	See technical spec.
MITF:	150 - 1200 years: See technical spec.

OPTIONS

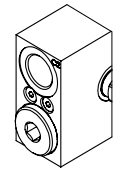
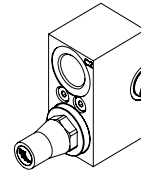

Plug with override screw

Normal plug

NOTES

When correctly adjusted for the specific excavator installation, these valves meet the requirement of ISO 8643.
For other configurations/quick codes not available in this catalogue page please consult factory

CURVES

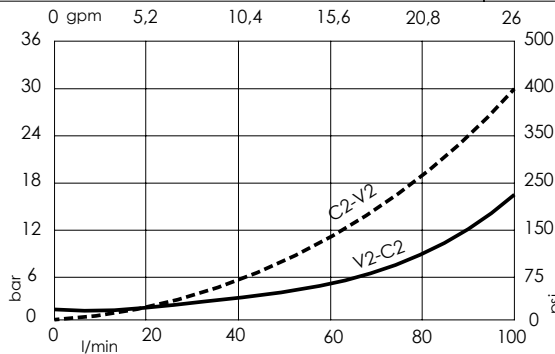

ORDERING CODES

Quick code	Description	Main ports size	Plug with override screw	Standard setting	Adjustment range	Pressure increase
ML000134	MLST-100-ALGR-00-G12-N420	V2,C2: G 1/2" Pil, T, M: G 1/4"	No	① 350 bar @5 l/min (5000 psi @1,3 gpm) ② 7.5 bar (100 psi) Crack. pr.	① 150-420 bar (2100-6000 psi) ② 3-15 bar (50-200 psi)	① 236 bar/turn (3400 psi/turn) ② 7 bar/turn (100 psi/turn)
ML000147	MLST-100-ALGR-00-G12-E420	V2,C2: G 1/2" Pil, T, M: G 1/4"	Yes	① 350 bar @5 l/min (5000 psi @1,3 gpm) ② 7.5 bar (100 psi) Crack. pr.	① 150-420 bar (2100-6000 psi) ② 3-15 bar (50-200 psi)	① 236 bar/turn (3400 psi/turn) ② 7 bar/turn (100 psi/turn)
ML000135	MLST-100-ALGR-00-J12-N420	V2,C2: JIS 1/2" Pil, T, M: JIS 1/4"	No	① 350 bar @5 l/min (5000 psi @1,3 gpm) ② 7.5 bar (100 psi) Crack. pr.	① 150-420 bar (2100-6000 psi) ② 3-15 bar (50-200 psi)	① 236 bar/turn (3400 psi/turn) ② 7 bar/turn (100 psi/turn)
ML000148	MLST-100-ALGR-00-J12-E420	V2,C2: JIS 1/2" Pil, T, M: JIS 1/4"	Yes	① 350 bar @5 l/min (5000 psi @1,3 gpm) ② 7.5 bar (100 psi) Crack. pr.	① 150-420 bar (2100-6000 psi) ② 3-15 bar (50-200 psi)	① 236 bar/turn (3400 psi/turn) ② 7 bar/turn (100 psi/turn)

CHECK AND METERING VALVE

MLST-100-ALGL

IN LINE VERSION
LEFT VERSION

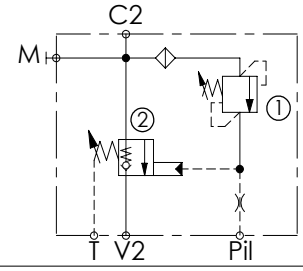
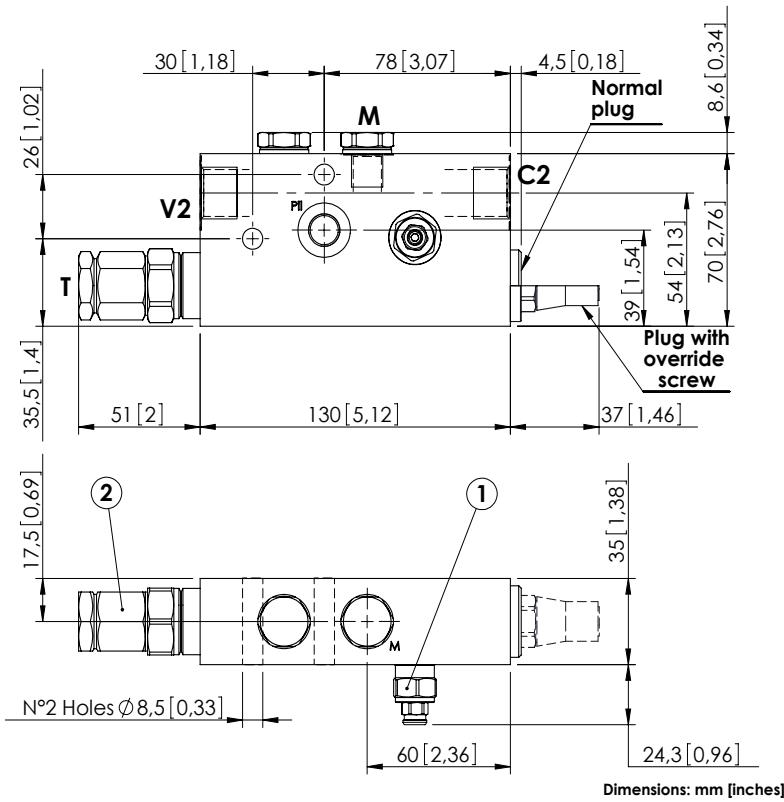

SPECIFICATIONS

Max. operating pressure:	420 bar (6000 psi)
Rated flow:	100 l/min (26 gpm)
Manifold:	Steel
Weight:	2,41 kg (5,27 lbs)
Contamination class to ISO 4406:	See technical spec.
MTF _d :	150 - 1200 years: See technical spec.

OPTIONS

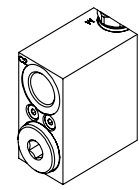
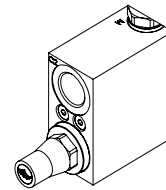

Plug with override screw

Normal plug

NOTES

When correctly adjusted for the specific excavator installation, these valves meet the requirement of ISO 8643.
For other configurations/quick codes not available in this catalogue page please consult factory

CURVES

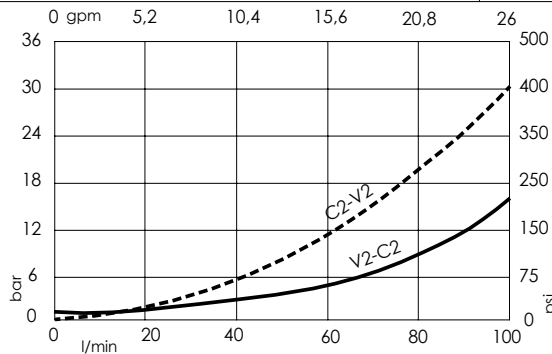

ORDERING CODES

Quick code	Description	Main ports size	Plug with override screw	Standard setting	Adjustment range	Pressure increase
ML000136	MLST-100-ALGL-00-G12-N420	V2,C2: G 1/2" P11, T, M: G 1/4"	No	① 350 bar @5 l/min (5000 psi @1,3 gpm) ② 7.5 bar (100 psi) Crack. pr.	① 150-420 bar (2100-6000 psi) ② 3-15 bar (50-200 psi)	① 236 bar/turn (3400 psi/turn) ② 7 bar/turn (100 psi/turn)
ML000149	MLST-100-ALGL-00-G12-E420	V2,C2: G 1/2" P11, T, M: G 1/4"	Yes	① 350 bar @5 l/min (5000 psi @1,3 gpm) ② 7.5 bar (100 psi) Crack. pr.	① 150-420 bar (2100-6000 psi) ② 3-15 bar (50-200 psi)	① 236 bar/turn (3400 psi/turn) ② 7 bar/turn (100 psi/turn)
ML000137	MLST-100-ALGL-00-J12-N420	V2,C2: JIS 1/2" P11, T, M: JIS 1/4"	No	① 350 bar @5 l/min (5000 psi @1,3 gpm) ② 7.5 bar (100 psi) Crack. pr.	① 150-420 bar (2100-6000 psi) ② 3-15 bar (50-200 psi)	① 236 bar/turn (3400 psi/turn) ② 7 bar/turn (100 psi/turn)
ML000150	MLST-100-ALGL-00-J12-E420	V2,C2: JIS 1/2" P11, T, M: JIS 1/4"	Yes	① 350 bar @5 l/min (5000 psi @1,3 gpm) ② 7.5 bar (100 psi) Crack. pr.	① 150-420 bar (2100-6000 psi) ② 3-15 bar (50-200 psi)	① 236 bar/turn (3400 psi/turn) ② 7 bar/turn (100 psi/turn)

CHECK AND METERING VALVE

MLST-150-ALGR

IN LINE VERSION
RIGHT VERSION

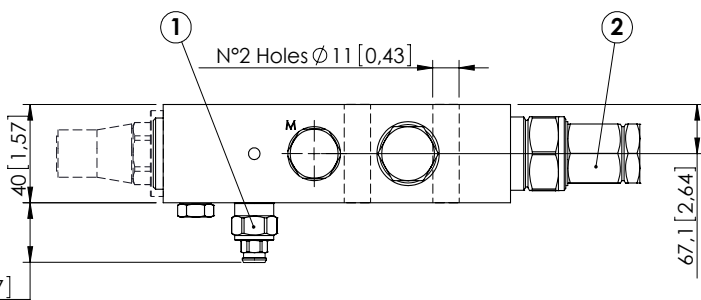
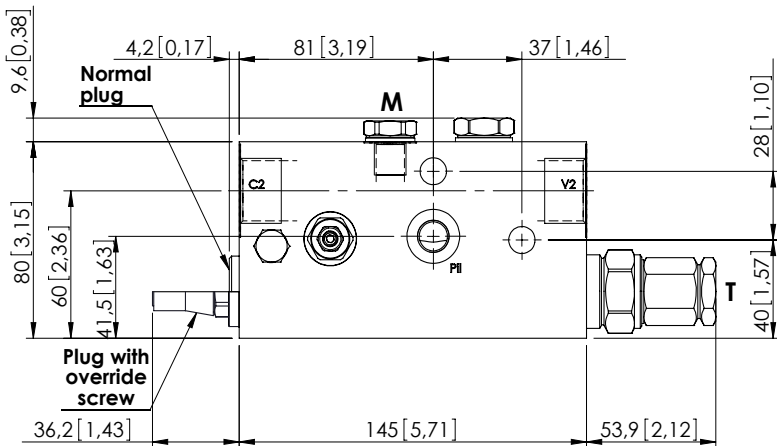

Dimensions: mm [inches]

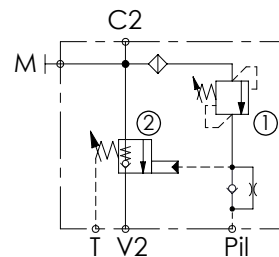

SPECIFICATIONS

Max. operating pressure:	420 bar (6000 psi)
Rated flow:	150 l/min (40 gpm)
Manifold:	Steel
Weight:	3,35 kg (7,39 lbs)
Contamination class to ISO 4406:	See technical spec.
MTF _d :	150 - 1200 years: See technical spec.

OPTIONS

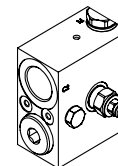
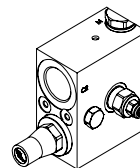

Plug with override screw

Normal plug

NOTES

When correctly adjusted for the specific excavator installation, these valves meet the requirement of ISO 8643.
For other configurations/quick codes not available in this catalogue page please consult factory

CURVES

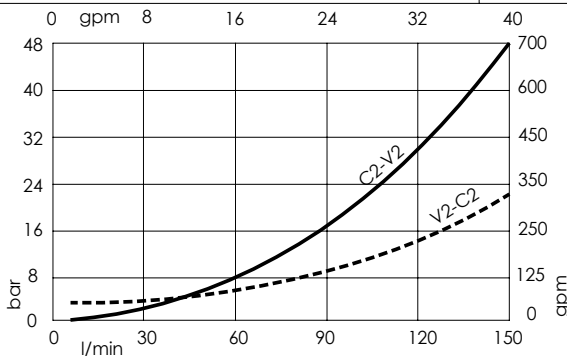

ORDERING CODES

Quick code	Description	Main ports size	Plug with override screw	Standard setting	Adjustment range	Pressure increase
ML000126	MLST-150-ALGR-00-G34-N420	V2,C2: G 3/4" P1,T,M: G 1/4"	No	① 350 bar @5 l/min (5000 psi @1,3 gpm) ② 7.5 bar (100 psi) Crack. pr.	① 150-420 bar (2100-6000 psi) ② 3-15 bar (50-200 psi)	① 236 bar/turn (3400 psi/turn) ② 8 bar/turn (100 psi/turn)
ML000011	MLST-150-ALGR-00-G34-E420	V2,C2: G 3/4" P1,T,M: G 1/4"	Yes	① 350 bar @5 l/min (5000 psi @1,3 gpm) ② 7.5 bar (100 psi) Crack. pr.	① 150-420 bar (2100-6000 psi) ② 3-15 bar (50-200 psi)	① 236 bar/turn (3400 psi/turn) ② 8 bar/turn (100 psi/turn)
ML000122	MLST-150-ALGR-00-U11-N420	V2,C2: 1 1/16-12 UNF P1,T: 9/16-18 UNF M: G 1/4"	No	① 350 bar @5 l/min (5000 psi @1,3 gpm) ② 7.5 bar (100 psi) Crack. pr.	① 150-420 bar (2100-6000 psi) ② 3-15 bar (50-200 psi)	① 236 bar/turn (3400 psi/turn) ② 8 bar/turn (100 psi/turn)
ML000029	MLST-150-ALGR-00-U11-E420	V2,C2: 1 1/16-12 UNF P1,T: 9/16-18 UNF M: G 1/4"	Yes	① 350 bar @5 l/min (5000 psi @1,3 gpm) ② 7.5 bar (100 psi) Crack. pr.	① 150-420 bar (2100-6000 psi) ② 3-15 bar (50-200 psi)	① 236 bar/turn (3400 psi/turn) ② 8 bar/turn (100 psi/turn)
ML000123	MLST-150-ALGR-00-J34-N420	V2,C2: 3/4" JIS P1,T,M: 1/4" JIS	No	① 350 bar @5 l/min (5000 psi @1,3 gpm) ② 7.5 bar (100 psi) Crack. pr.	① 150-420 bar (2100-6000 psi) ② 3-15 bar (50-200 psi)	① 236 bar/turn (3400 psi/turn) ② 7 bar/turn (100 psi/turn)
ML000105	MLST-150-ALGR-00-J34-E420	V2,C2: 3/4" JIS P1,T,M: 1/4" JIS	Yes	① 350 bar @5 l/min (5000 psi @1,3 gpm) ② 7.5 bar (100 psi) Crack. pr.	① 150-420 bar (2100-6000 psi) ② 3-15 bar (50-200 psi)	① 236 bar/turn (3400 psi/turn) ② 7 bar/turn (100 psi/turn)

CHECK AND METERING VALVE

MLST-150-ALGL

IN LINE VERSION
LEFT VERSION

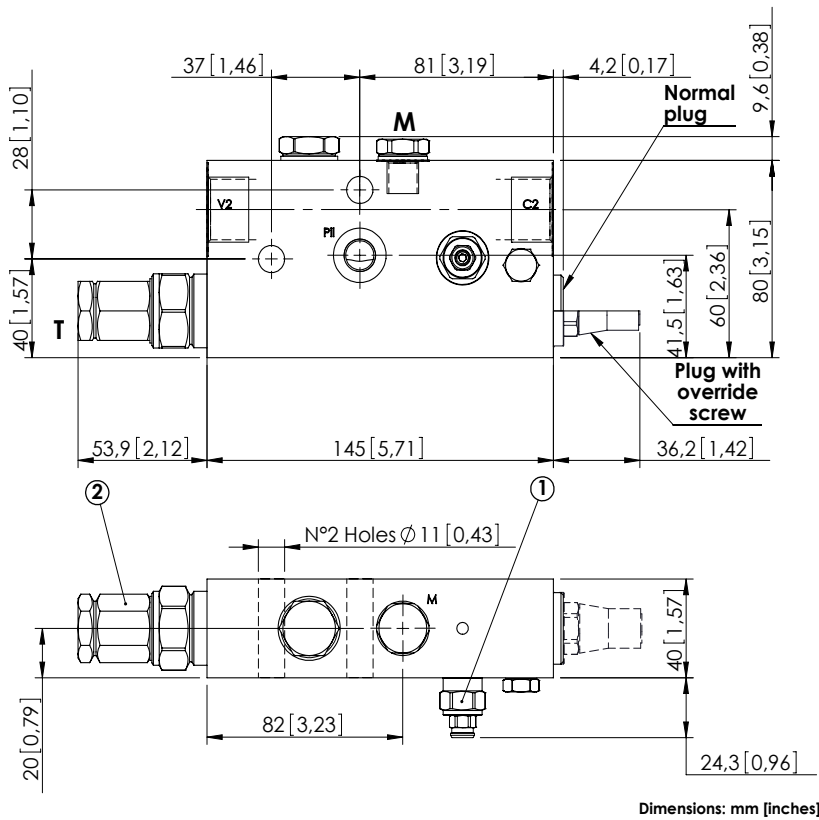

Dimensions: mm [inches]

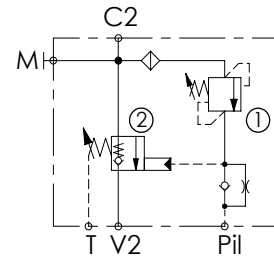

SPECIFICATIONS

Max. operating pressure:	420 bar (6000 psi)
Rated flow:	150 l/min (40 gpm)
Manifold:	Steel
Weight:	3,35 kg (7,39 lbs)
Contamination class to ISO 4406:	See technical spec.
MTTF:	150 - 1200 years: See technical spec.

OPTIONS

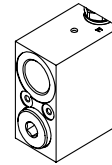

Normal plug

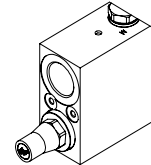

Plug with override screw

NOTES

When correctly adjusted for the specific excavator installation, these valves meet the requirement of ISO 8643.
For other configurations/quick codes not available in this catalogue page please consult factory

CURVES

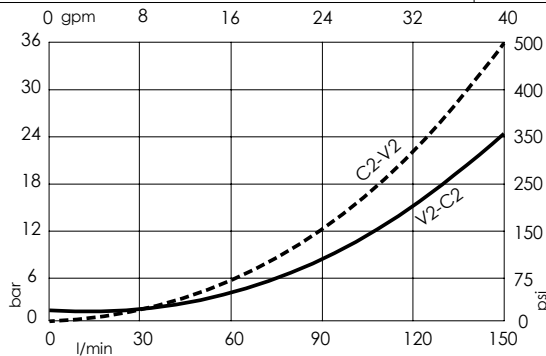

ORDERING CODES

Quick code	Description	Main ports size	Plug with override screw	Standard setting	Adjustment range	Pressure increase
ML000121	MLST-150-ALGL-00-G34-N420	V2,C2: G 3/4" Pii,T,M: G 1/4"	No	① 350 bar @5 l/min (5000 psi @1,3 gpm) ② 7.5 bar (100 psi) Crack. pr.	① 150-420 bar (2100-6000 psi) ② 3-15 bar (50-200 psi)	① 236 bar/turn (3400 psi/turn) ② 8 bar/turn (100 psi/turn)
ML000010	MLST-150-ALGL-00-G34-E420	V2,C2: G 3/4" Pii,T,M: G 1/4"	Yes	① 350 bar @5 l/min (5000 psi @1,3 gpm) ② 7.5 bar (100 psi) Crack. pr.	① 150-420 bar (2100-6000 psi) ② 3-15 bar (50-200 psi)	① 236 bar/turn (3400 psi/turn) ② 8 bar/turn (100 psi/turn)
ML000124	MLST-150-ALGL-00-U11-N420	V2,C2: 1 1/16-12 UNF Pii,T: 9/16-18 UNF M: G 1/4"	No	① 350 bar @5 l/min (5000 psi @1,3 gpm) ② 7.5 bar (100 psi) Crack. pr.	① 150-420 bar (2100-6000 psi) ② 3-15 bar (50-200 psi)	① 236 bar/turn (3400 psi/turn) ② 8 bar/turn (100 psi/turn)
ML000030	MLST-150-ALGL-00-U11-E420	V2,C2: 1 1/16-12 UNF Pii,T: 9/16-18 UNF M: G 1/4"	Yes	① 350 bar @5 l/min (5000 psi @1,3 gpm) ② 7.5 bar (100 psi) Crack. pr.	① 150-420 bar (2100-6000 psi) ② 3-15 bar (50-200 psi)	① 236 bar/turn (3400 psi/turn) ② 8 bar/turn (100 psi/turn)
ML000125	MLST-150-ALGL-00-J34-N420	V2,C2: 3/4" JIS Pii,T,M: 1/4" JIS	No	① 350 bar @5 l/min (5000 psi @1,3 gpm) ② 7.5 bar (100 psi) Crack. pr.	① 150-420 bar (2100-6000 psi) ② 3-15 bar (50-200 psi)	① 236 bar/turn (3400 psi/turn) ② 8 bar/turn (100 psi/turn)
ML000104	MLST-150-ALGL-00-J34-E420	V2,C2: 3/4" JIS Pii,T,M: 1/4" JIS	Yes	① 350 bar @5 l/min (5000 psi @1,3 gpm) ② 7.5 bar (100 psi) Crack. pr.	① 150-420 bar (2100-6000 psi) ② 3-15 bar (50-200 psi)	① 236 bar/turn (3400 psi/turn) ② 8 bar/turn (100 psi/turn)

CHECK AND METERING VALVE

MLLT-100-AAGN

FLANGED TYPE
1/2" SAE 6000

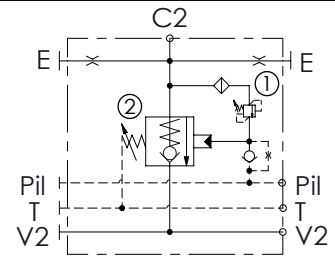
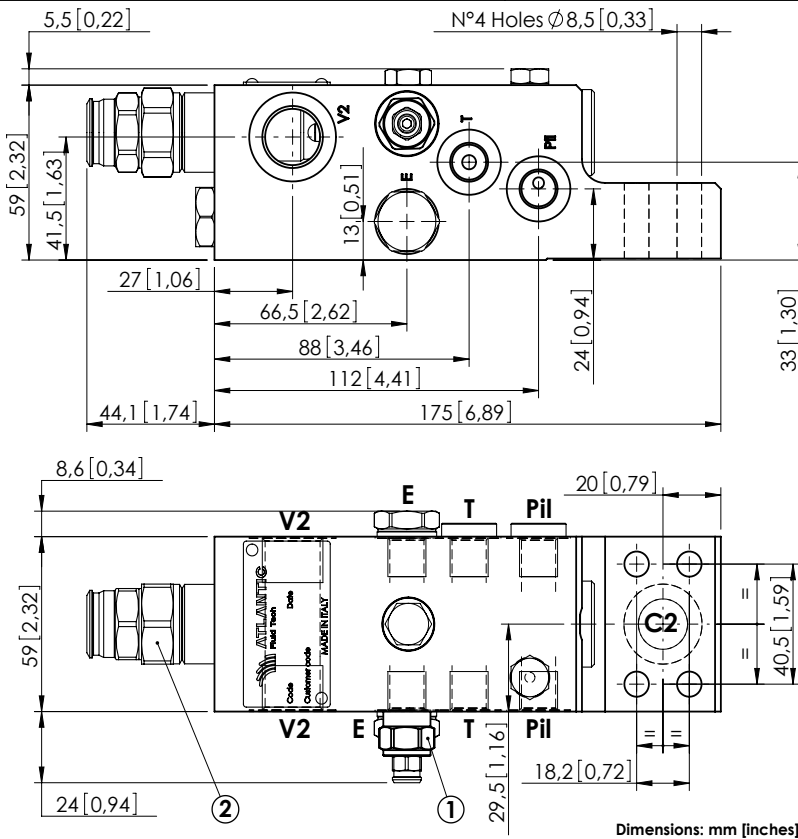

SPECIFICATIONS

Max. operating pressure:	420 bar (6000 psi)
Rated flow:	100 l/min (26 gpm)
Manifold:	Steel
Weight:	3.87 kg (8.53 lbs)
Contamination class to ISO 4406:	See technical spec.
MTTF _a :	150 - 1200 years: See technical spec.

NOTES

When correctly adjusted for the specific excavator installation, these valves meet the requirement of ISO 8643.
For other configurations/quick codes not available in this catalogue page please consult factory

CURVES

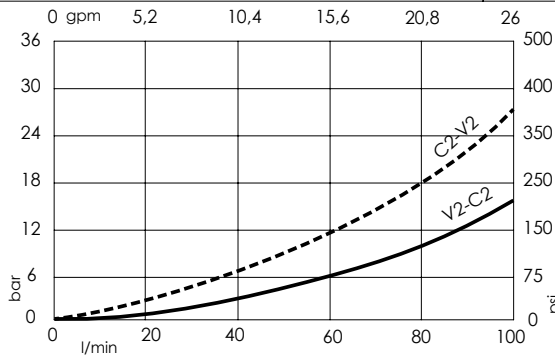

ORDERING CODES

Quick code	Description	Main ports size	Standard setting	Adjustment range	Pressure increase
ML000130	MLLT-100-AAGN-00-S12-N420	C2: 1/2" SAE 6000 V2: G 1/2" E,Pii,T: G 1/4	① 350 bar @5 l/min (5000 psi @1.3 gpm) ② 7.5 bar (100 psi) Crack. pr.	① 150-420 bar (2100-6000 psi) ② 3-15 bar (50-200 psi)	① 236 bar/turn (3400 psi/turn) ② 6 bar/turn (85 psi/turn)

CHECK AND METERING VALVE

MLLT-150-AAGN

FLANGED TYPE
1/2" SAE 6000

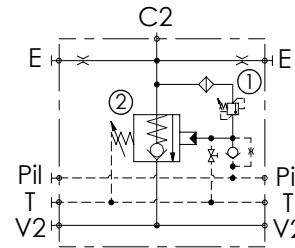
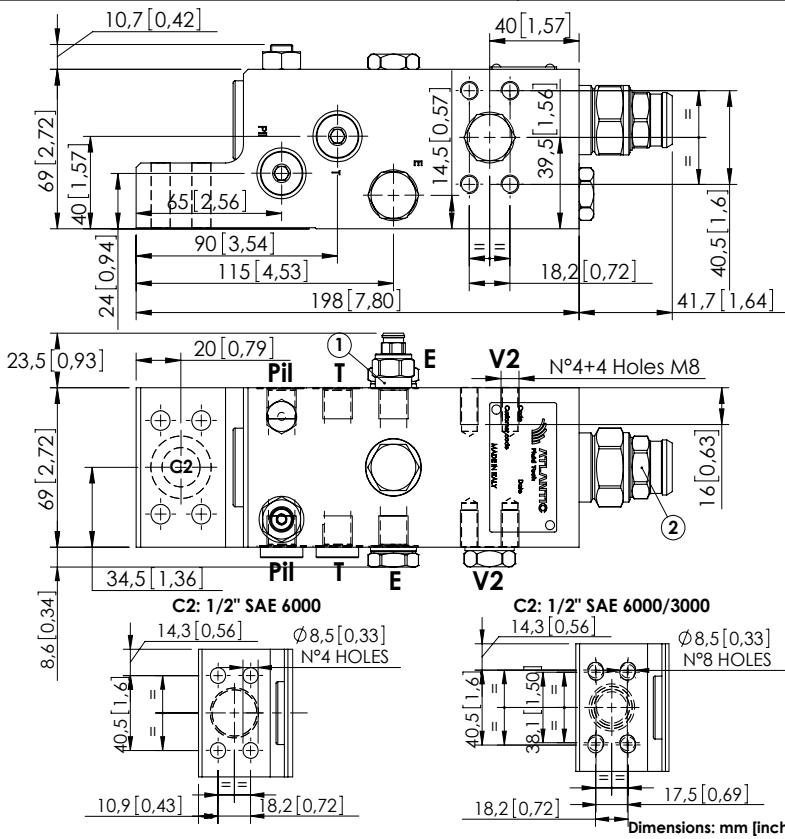

SPECIFICATIONS

Max. operating pressure:	420 bar (6000 psi)
Rated flow:	150 l/min (40 gpm)
Manifold:	Steel
Weight:	6,09 kg (13,43 lbs)
Contamination class to ISO 4406:	See technical spec.
MTTF _a :	150 - 1200 years: See technical spec.

NOTES

When correctly adjusted for the specific excavator installation, these valves meet the requirement of ISO 8643.
For other configurations/quick codes not available in this catalogue page please consult factory

CURVES

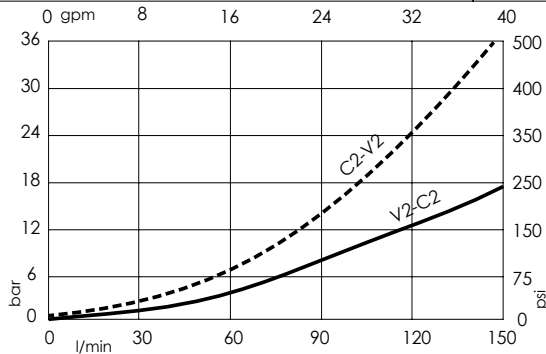

ORDERING CODES

Quick code	Description	Main ports size	Standard setting	Adjustment range	Pressure increase
ML000082	MLLT-150-AAGN-00-S12-N420	V2,C2: 1/2" SAE 6000 E,Pil,T: G 1/4"	① 350 bar @5 l/min (5000 psi @1,3 gpm) ② 7.5 bar (100 psi) Crack. pr.	① 150-420 bar (2100-6000 psi) ② 3-15 bar (50-200 psi)	① 236 bar/turn (3400 psi/turn) ② 5 bar/turn (70 psi/turn)
ML000083	MLLT-150-ASGN-00-S12-N420	C2: 1/2" SAE 6000/3000 V2: 1/2" SAE 6000 E,Pil,T: G 1/4"	① 350 bar @5 l/min (5000 psi @1,3 gpm) ② 7.5 bar (100 psi) Crack. pr.	① 150-420 bar (2100-6000 psi) ② 3-15 bar (50-200 psi)	① 236 bar/turn (3400 psi/turn) ② 5 bar/turn (70 psi/turn)

CHECK AND METERING VALVE

MLLT-200-AAGR

FLANGED TYPE
3/4" SAE 6000

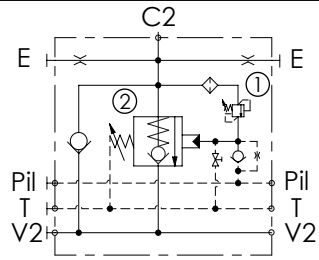
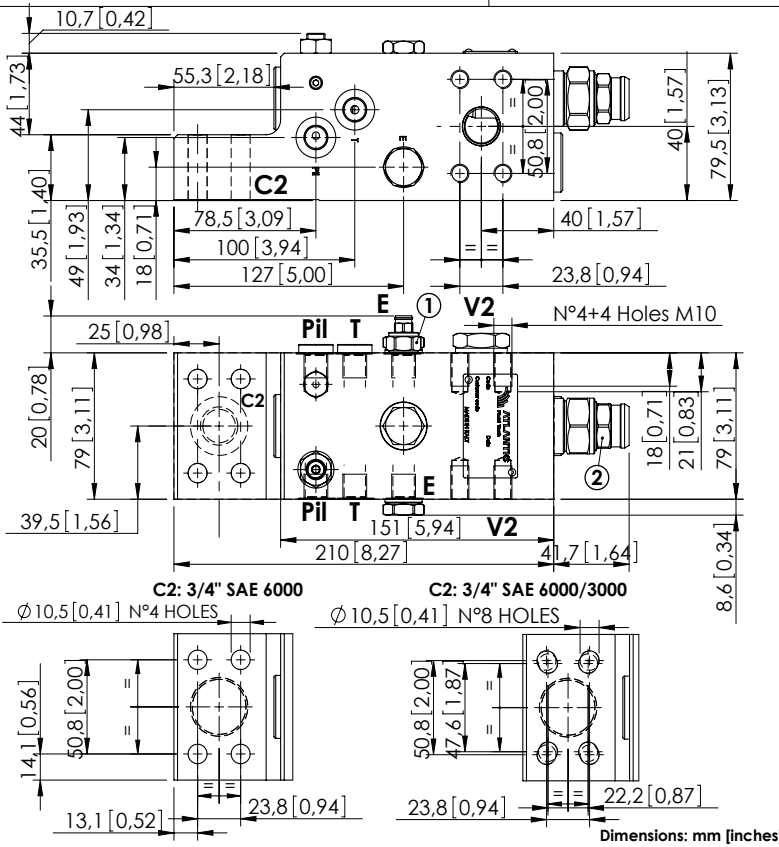

SPECIFICATIONS

Max. operating pressure:	420 bar (6000 psi)
Rated flow:	250 l/min (66 gpm)
Manifold:	Steel
Weight:	8,17 kg (17,97 lbs)
Contamination class to ISO 4406:	See technical spec.
MTTF _d :	150 - 1200 years: See technical spec.

NOTES

When correctly adjusted for the specific excavator installation, these valves meet the requirement of ISO 8643.
For other configurations/quick codes not available in this catalogue page please consult factory

CURVES

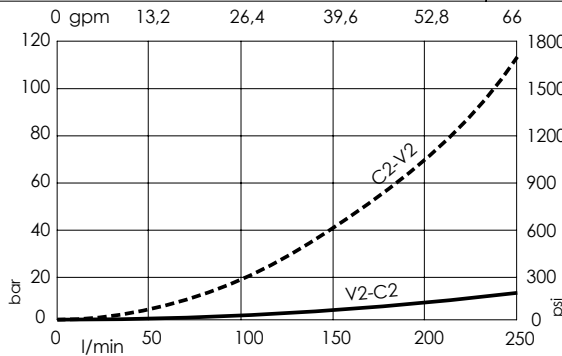

ORDERING CODES

Quick code	Description	Main ports size	Standard setting	Adjustment range	Pressure increase
ML000075	MLLT-200-AAGR-00-S34-N420	V2,C2: 3/4" SAE 6000 E,Pil,T: G 1/4"	① 350 bar @5 l/min (5000 psi @1,3 gpm) ② 7.5 bar (100 psi) Crack. pr.	① 150-420 bar (2100-6000 psi) ② 3-15 bar (50-200 psi)	① 236 bar/turn (3400 psi/turn) ② 5 bar/turn (70 psi/turn)
ML000076	MLLT-200-AAUR-00-S34-N420	V2,C2: 3/4" SAE 6000 E,Pil,T: 9/16-18 UNF-2B	① 350 bar @5 l/min (5000 psi @1,3 gpm) ② 7.5 bar (100 psi) Crack. pr.	① 150-420 bar (2100-6000 psi) ② 3-15 bar (50-200 psi)	① 236 bar/turn (3400 psi/turn) ② 5 bar/turn (70 psi/turn)
ML000091	MLLT-200-ASGR-00-S34-N420	V2: 3/4" SAE 6000 C2: 3/4" SAE 6000/3000 E,Pil,T: G 1/4"	① 350 bar @5 l/min (5000 psi @1,3 gpm) ② 7.5 bar (100 psi) Crack. pr.	① 150-420 bar (2100-6000 psi) ② 3-15 bar (50-200 psi)	① 236 bar/turn (3400 psi/turn) ② 5 bar/turn (70 psi/turn)
ML000112	MLLT-200-ASJR-00-S34-N420	V2,C2: 3/4" SAE 6000 E,Pil,T: 1/4" JIS	① 350 bar @5 l/min (5000 psi @1,3 gpm) ② 7.5 bar (100 psi) Crack. pr.	① 150-420 bar (2100-6000 psi) ② 3-15 bar (50-200 psi)	① 236 bar/turn (3400 psi/turn) ② 5 bar/turn (70 psi/turn)

CHECK AND METERING VALVE

MLLT-200-AAGR

FLANGED TYPE
1" SAE 6000

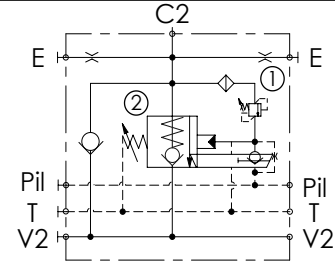
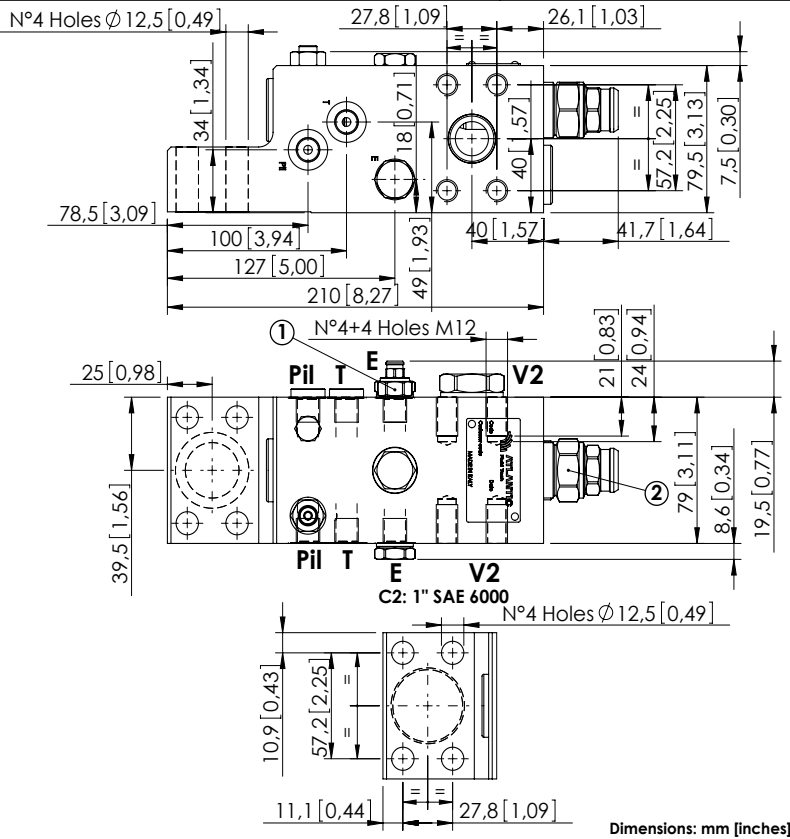

SPECIFICATIONS

Max. operating pressure:	420 bar (6000 psi)
Rated flow:	250 l/min (66 gpm)
Manifold:	Steel
Weight:	8,01 kg (17,66 lbs)
Contamination class to ISO 4406:	See technical spec.
MTTF:	150 - 1200 years: See technical spec.

NOTES

When correctly adjusted for the specific excavator installation, these valves meet the requirement of ISO 8643.
For other configurations/quick codes not available in this catalogue page please consult factory

CURVES

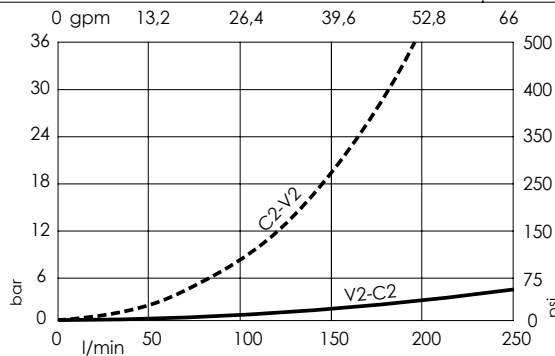

ORDERING CODES

Quick code	Description	Main ports size	Standard setting	Adjustment range	Pressure increase
ML000138	MLLT-200-AAGR-00-S10-N420	V2,C2: 1" SAE 6000 E,Pil,T: G 1/4"	① 350 bar @5 l/min (5000 psi @1,3 gpm) ② 7.5 bar (100 psi) Crack. pr.	① 150-420 bar (2100-6000 psi) ② 3-15 bar (50-200 psi)	① 236 bar/turn (3400 psi/turn) ② 5 bar/turn (70 psi/turn)

CHECK AND METERING VALVE

MLLT-300-AAGR

FLANGED TYPE
3/4" SAE 6000

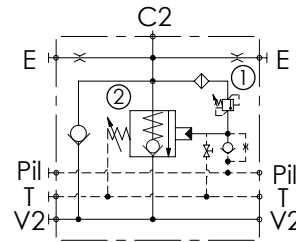
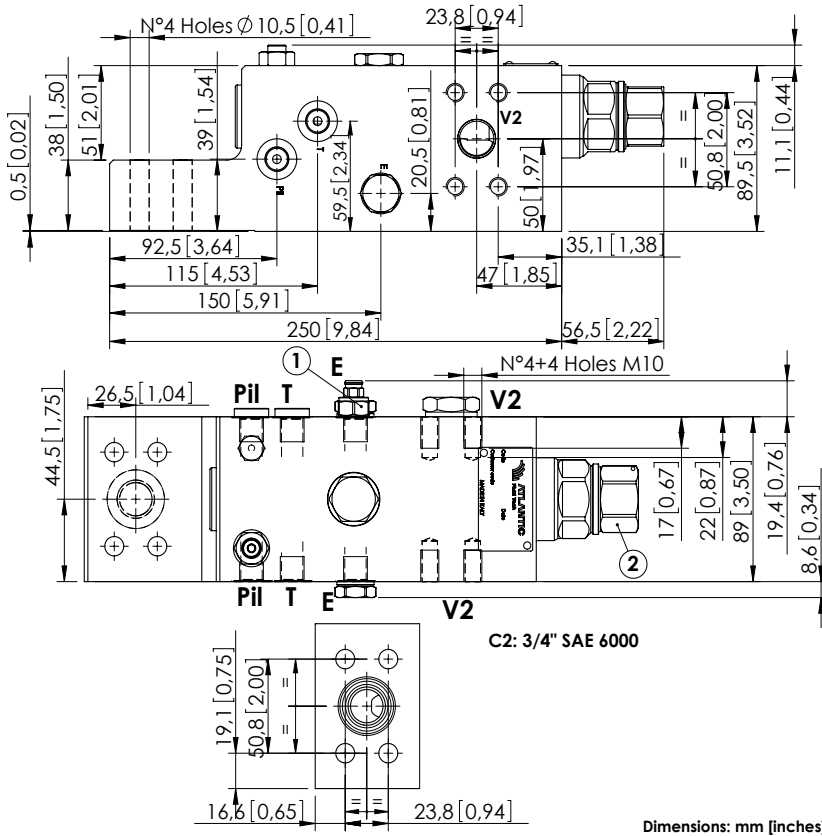

SPECIFICATIONS

Max. operating pressure:	420 bar (6000 psi)
Rated flow:	350 l/min (92 gpm)
Manifold:	Steel
Weight:	12,27 kg (27.05 lbs)
Contamination class to ISO 4406:	See technical spec.
MTF _d :	150 - 1200 years: See technical spec.

NOTES

When correctly adjusted for the specific excavator installation, these valves meet the requirement of ISO 8643.
For other configurations/quick codes not available in this catalogue page please consult factory

CURVES

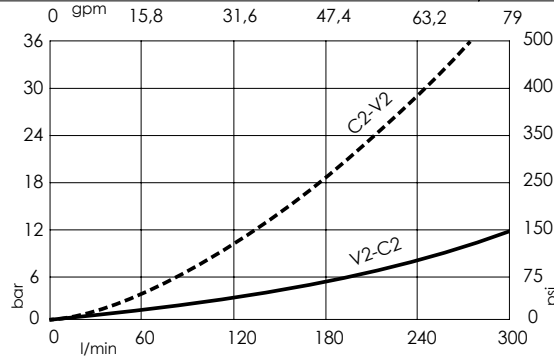

ORDERING CODES

Quick code	Description	Main ports size	Standard setting	Adjustment range	Pressure increase
ML000106	MLLT-300-AAGR-00-S34-N420	V2,C2: 3/4" SAE 6000 E,Pil,T: G 1/4"	① 350 bar @5 l/min (5000 psi @1.3 gpm) ② 7.5 bar (100 psi) Crack. pr.	① 150-420 bar (2100-6000 psi) ② 3-15 bar (50-200 psi)	① 236 bar/turn (3400 psi/turn) ② 3.4 bar/turn (50 psi/turn)
ML000115	MLLT-300-AAJR-00-S34-N420	V2,C2: 3/4" SAE 6000 E,Pil,T: 1/4" JIS	① 350 bar @5 l/min (5000 psi @1.3 gpm) ② 7.5 bar (100 psi) Crack. pr.	① 150-420 bar (2100-6000 psi) ② 3-15 bar (50-200 psi)	① 236 bar/turn (3400 psi/turn) ② 3.4 bar/turn (50 psi/turn)

CHECK AND METERING VALVE

MLLT-300-AAGR

FLANGED TYPE
1" SAE 6000

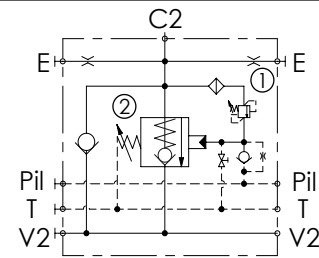
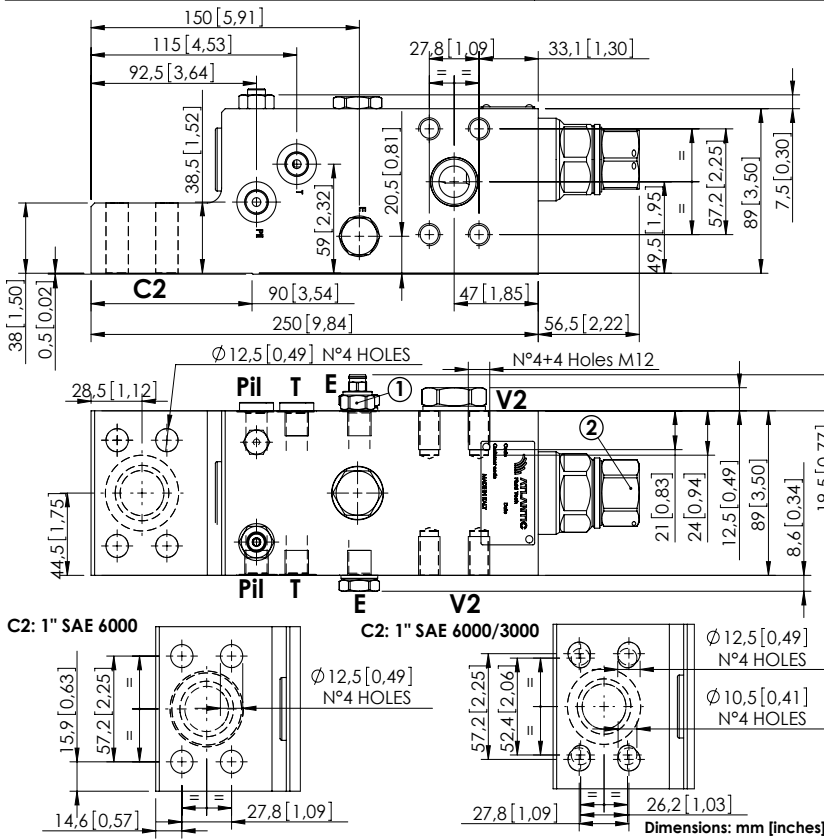

SPECIFICATIONS

Max. operating pressure:	420 bar (6000 psi)
Rated flow:	400 l/min (106 gpm)
Manifold:	Steel
Weight:	12,14 kg (26,76 lbs)
Contamination class to ISO 4406:	See technical spec.
MTF _d :	150 - 1200 years: See technical spec.

NOTES

When correctly adjusted for the specific excavator installation, these valves meet the requirement of ISO 8643.
For other configurations/quick codes not available in this catalogue page please consult factory

CURVES

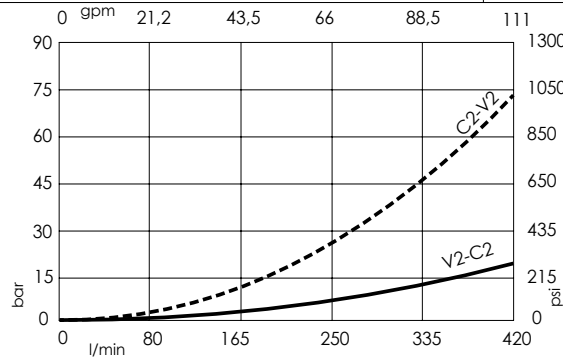

ORDERING CODES

Quick code	Description	Main ports size	Standard setting	Adjustment range	Pressure increase
ML000079	MLLT-300-AAGR-00-S10-N420	V2,C2: 1" SAE 6000 E,Pil,T: G 1/4"	① 350 bar @5 l/min (5000 psi @1,3 gpm) ② 7.5 bar (100 psi) Crack. pr.	① 150-420 bar (2100-6000 psi) ② 3-15 bar (50-200 psi)	① 236 bar/turn (3400 psi/turn) ② 3,4 bar/turn (50 psi/turn)
ML000080	MLLT-300-AAUR-00-S10-N420	V2,C2: 1" SAE 6000 E,Pil,T: 9/16-18 UNF-2B	① 350 bar @5 l/min (5000 psi @1,3 gpm) ② 7.5 bar (100 psi) Crack. pr.	① 150-420 bar (2100-6000 psi) ② 3-15 bar (50-200 psi)	① 236 bar/turn (3400 psi/turn) ② 3,4 bar/turn (50 psi/turn)
ML000081	MLLT-300-ASGR-00-S10-N420	V2: 1" SAE 6000 C2: 1" SAE 6000/3000 E, Pil, T: G 1/4"	① 350 bar @5 l/min (5000 psi @1,3 gpm) ② 7.5 bar (100 psi) Crack. pr.	① 150-420 bar (2100-6000 psi) ② 3-15 bar (50-200 psi)	① 236 bar/turn (3400 psi/turn) ② 3,4 bar/turn (50 psi/turn)
ML000177	MLLT-300-ASJR-00-S10-N420	V2,C2: 1" SAE 6000 E, Pil, T: JIS 1/4"	① 350 bar @5 l/min (5000 psi @1,3 gpm) ② 7.5 bar (100 psi) Crack. pr.	① 150-420 bar (2100-6000 psi) ② 3-15 bar (50-200 psi)	① 236 bar/turn (3400 psi/turn) ② 3,4 bar/turn (50 psi/turn)

CHECK AND METERING VALVE

MLLT-300-AAGN

FLANGED TYPE
1 1/4" SAE 6000

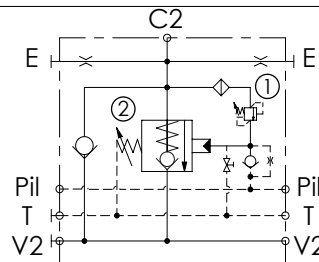
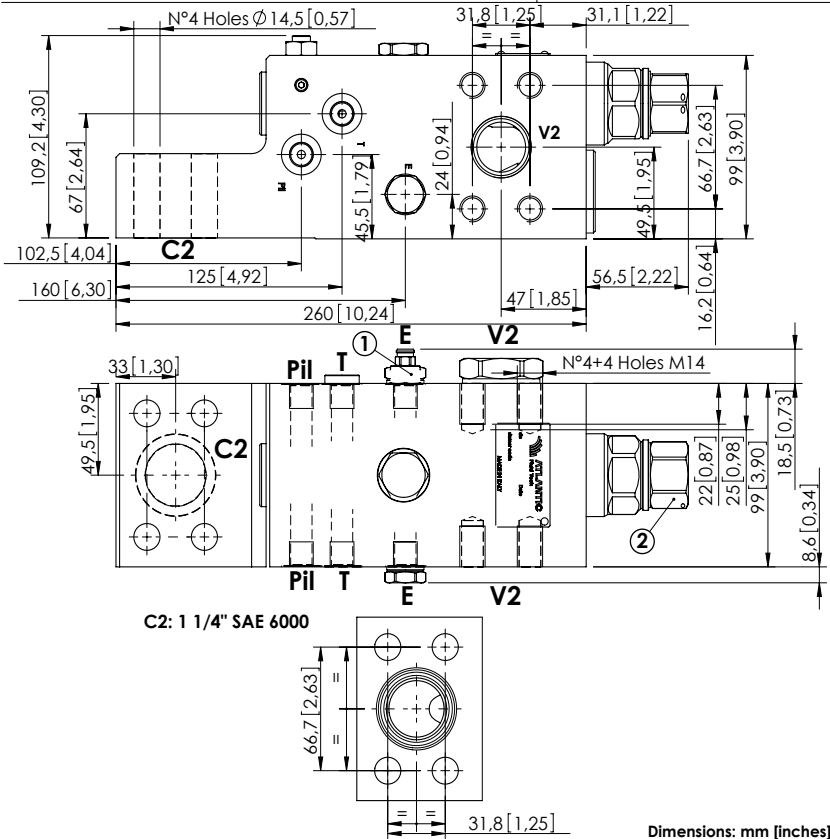

SPECIFICATIONS

Max. operating pressure:	420 bar (6000 psi)
Rated flow:	500 l/min (132 gpm)
Manifold:	Steel
Weight:	15.08 kg (33.25 lbs)
Contamination class to ISO 4406:	See technical spec.
MTF _d :	150 - 1200 years: See technical spec.

NOTES

When correctly adjusted for the specific excavator installation, these valves meet the requirement of ISO 8643.
For other configurations/quick codes not available in this catalogue page please consult factory

CURVES

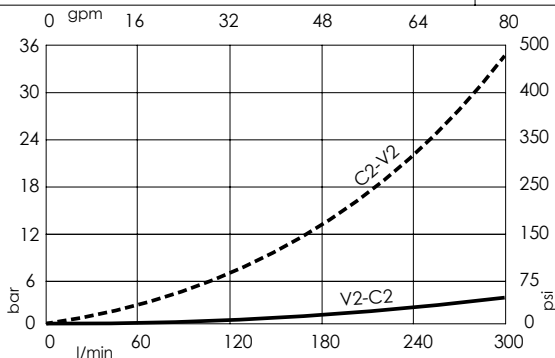

ORDERING CODES

Quick code	Description	Main ports size	Standard setting	Adjustment range	Pressure increase
ML000077	MLLT-300-AAGN-00-S11-N420	V2,C2: 1 1/4" SAE 6000 E,Pii,T: G 1/4"	① 350 bar @5 l/min (5000 psi @1,3 gpm) ② 7.5 bar (100 psi) Crack. pr.	① 150-420 bar (2100-6000 psi) ② 3-15 bar (50-200 psi)	① 236 bar/turn (3400 psi/turn) ② 3,4 bar/turn (50 psi/turn)
ML000078	MLLT-300-AAUN-00-S11-N420	V2,C2: 1 1/4" SAE 6000 E,Pii,T: 9/16-18 UNF-2B	① 350 bar @5 l/min (5000 psi @1,3 gpm) ② 7.5 bar (100 psi) Crack. pr.	① 150-420 bar (2100-6000 psi) ② 3-15 bar (50-200 psi)	① 236 bar/turn (3400 psi/turn) ② 3,4 bar/turn (50 psi/turn)
ML000131	MLLT-300-AAJN-00-S11-N420	V2,C2: 1 1/4" SAE 6000 E,Pii,T: 1/4" JIS	① 350 bar @5 l/min (5000 psi @1,3 gpm) ② 7.5 bar (100 psi) Crack. pr.	① 150-420 bar (2100-6000 psi) ② 3-15 bar (50-200 psi)	① 236 bar/turn (3400 psi/turn) ② 3,4 bar/turn (50 psi/turn)

CHECK AND METERING VALVE

MLLT-500-AAJN

FLANGED TYPE
3/4" SAE 6000

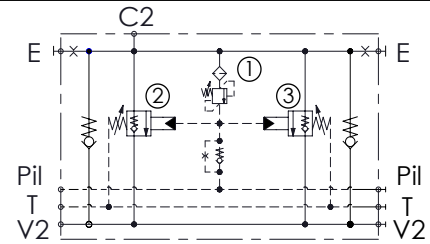
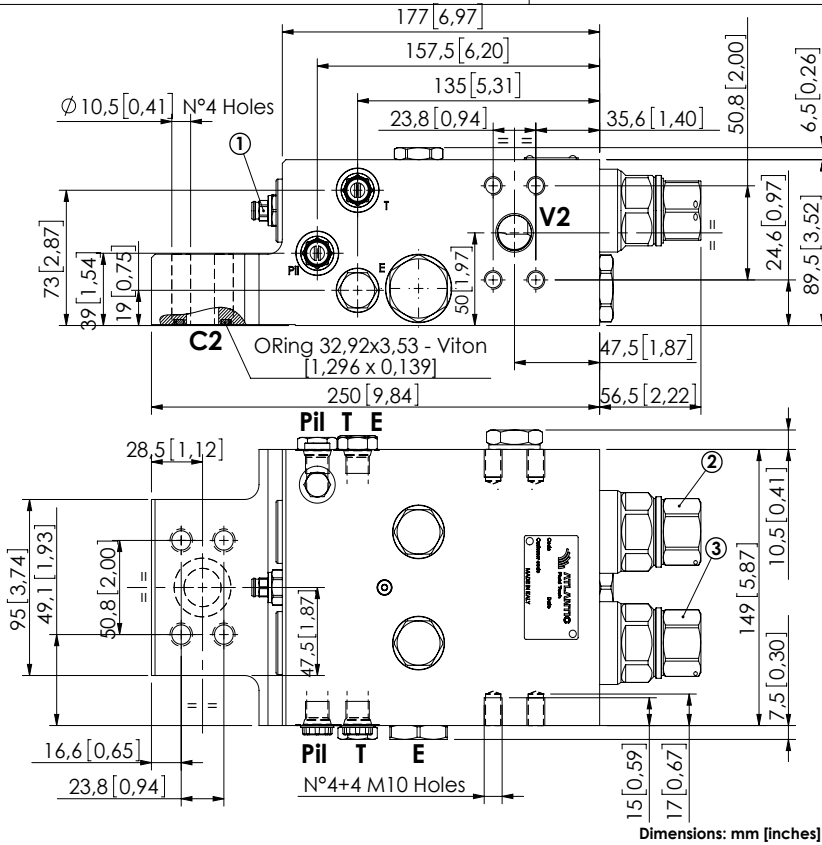

SPECIFICATIONS

Max. operating pressure:	420 bar (6000 psi)
Rated flow:	500 l/min (132 gpm)
Manifold:	Steel
Weight:	19.63 kg (43,28 lbs)
Contamination class to ISO 4406:	See technical spec.
MTTFd:	150 - 1200 years: See technical spec.

NOTES

When correctly adjusted for the specific excavator installation, these valves meet the requirement of ISO 8643.
For other configurations/quick codes not available in this catalogue page please consult factory

CURVES

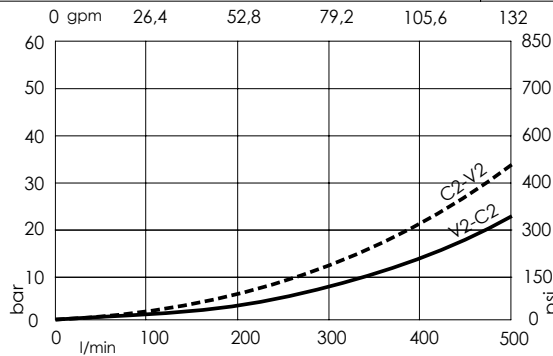

ORDERING CODES

Quick code	Description	Main ports size	Standard setting	Adjustment range	Pressure increase
ML000263	MLLT-500-AAJN-00-S34-N420	V2,C2: 3/4" SAE 6000 E,Pil,T: JIS 1/4"	① 350 bar @5 l/min (5000 psi @1,3 gpm) ②③ 7.5 bar (100 psi) Crack. pr.	① 150-420 bar (2100-6000 psi) ②③ 3-15 bar (50-200 psi)	① 236 bar/turn (3400 psi/turn) ②③ 3,4 bar/turn (50 psi/turn)

CHECK AND METERING VALVE

MLLT-500-AAGN

FLANGED TYPE
1" SAE 6000

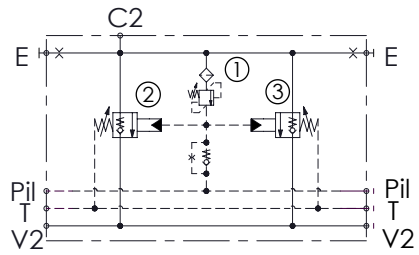
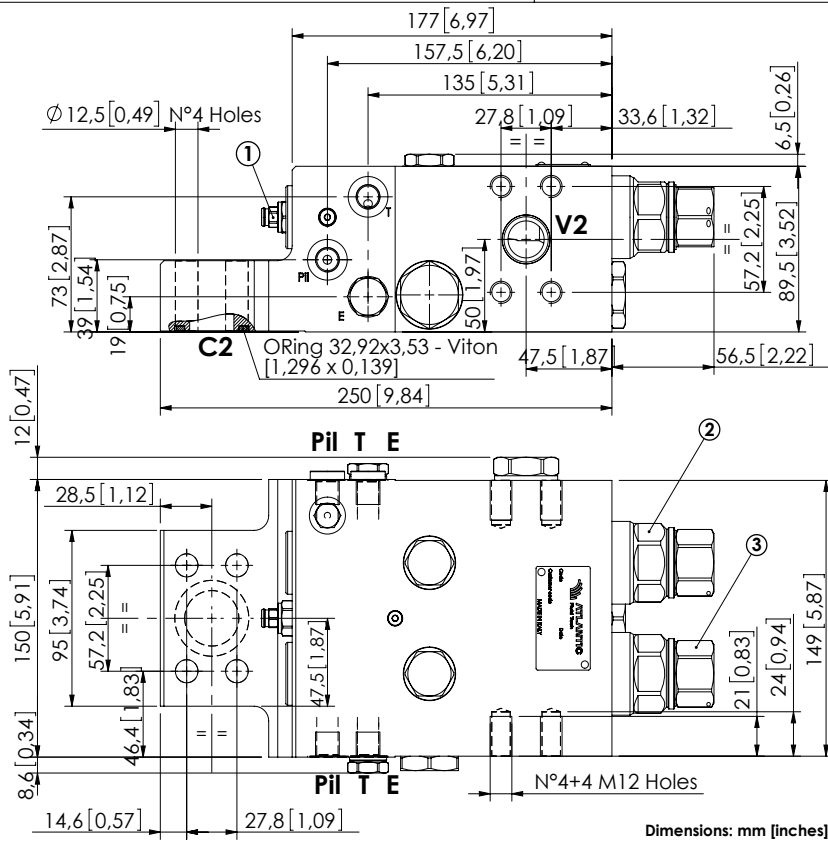

SPECIFICATIONS

Max. operating pressure:	420 bar (6000 psi)
Rated flow:	500 l/min (132 gpm)
Manifold:	Steel
Weight:	19.48 kg (42.95 lbs)
Contamination class to ISO 4406:	See technical spec.
MTF _d :	150 - 1200 years: See technical spec.

NOTES

When correctly adjusted for the specific excavator installation, these valves meet the requirement of ISO 8643.
For other configurations/quick codes not available in this catalogue page please consult factory

CURVES

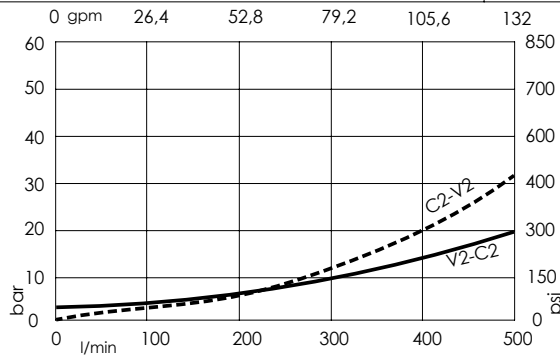

ORDERING CODES

Quick code	Description	Main ports size	Standard setting	Adjustment range	Pressure increase
ML000113	MLLT-500-AAGN-00-S10-N420	V2,C2: 1" SAE 6000 E,Pil,T: G 1/4"	① 350 bar @5 l/min(5300 psi @1.3 gpm) ② 10 bar (150 psi) Crack. pr. ③ 7.5 bar (100 psi) Crack. pr.	① 150-420 bar (2100-6000 psi) ② ③ 3-15 bar (50-200 psi)	① 236 bar/turn (3400 psi/turn) ② ③ 3,4 bar/turn (50 psi/turn)

CHECK AND METERING VALVE

MLL-550-AAGN

FLANGED TYPE
1" 1/4 SAE 6000

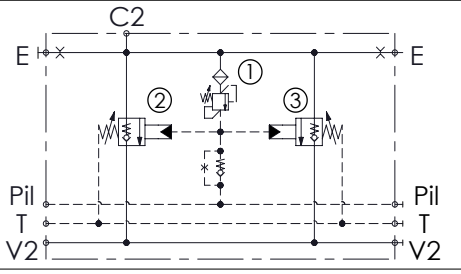
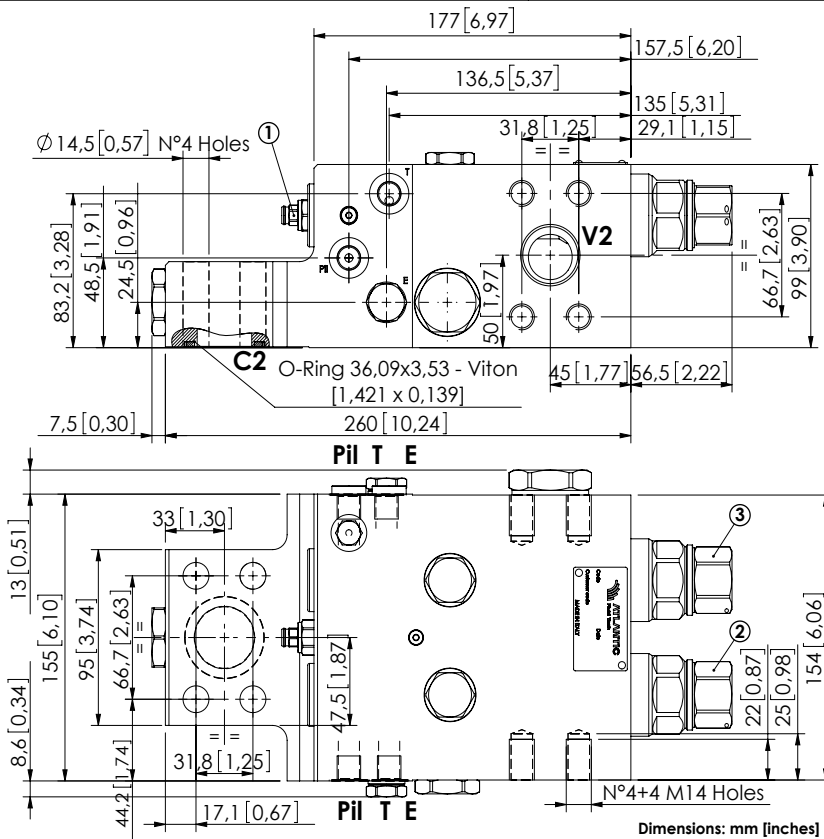

SPECIFICATIONS

Max. operating pressure:	420 bar (6000 psi)
Rated flow:	550 l/min (145 gpm)
Manifold:	Steel
Weight:	22.66 kg (49,96 lbs)
Contamination class to ISO 4406:	See technical spec.
MTTFd:	150 - 1200 years: See technical spec.

NOTES

When correctly adjusted for the specific excavator installation, these valves meet the requirement of ISO 8643.
For other configurations/quick codes not available in this catalogue page please consult factory

CURVES

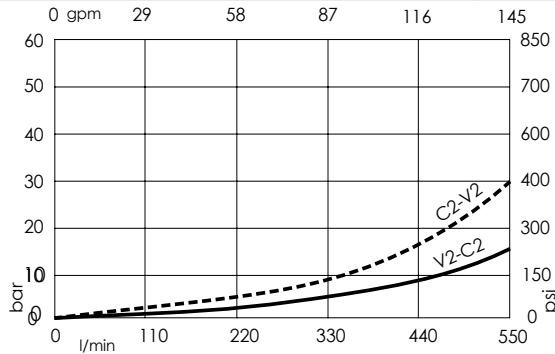

ORDERING CODES

Quick code	Description	Main ports size	Standard setting	Adjustment range	Pressure increase
ML000161	MLLT-500-AAGN-00-S11-N420	V2,C2:1" 1/4 SAE 6000 E,Pil,T:G 1/4"	① 350 bar @5 l/min (5000 psi @1,3 gpm) ② ③ 7.5 bar (100 psi) Crack. pr.	① 150-420 bar (2100-6000 psi) ② ③ 3-15 bar (50-200 psi)	① 236 bar/turn (3400 psi/turn) ② ③ 3,4 bar/turn (50 psi/turn)

CHECK AND METERING VALVE

MLLT-700-AAGN

FLANGED TYPE
1" 1/4 SAE 6000

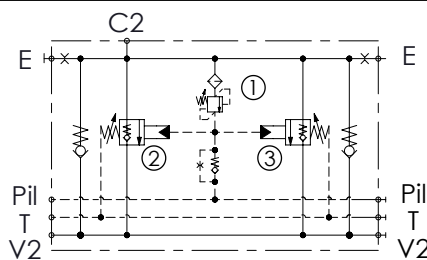
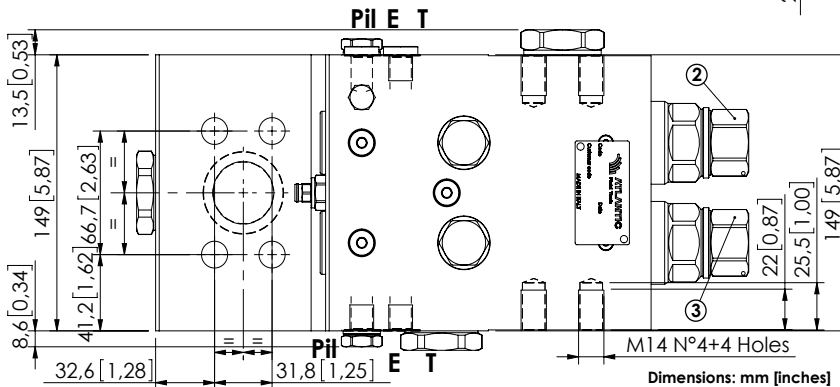
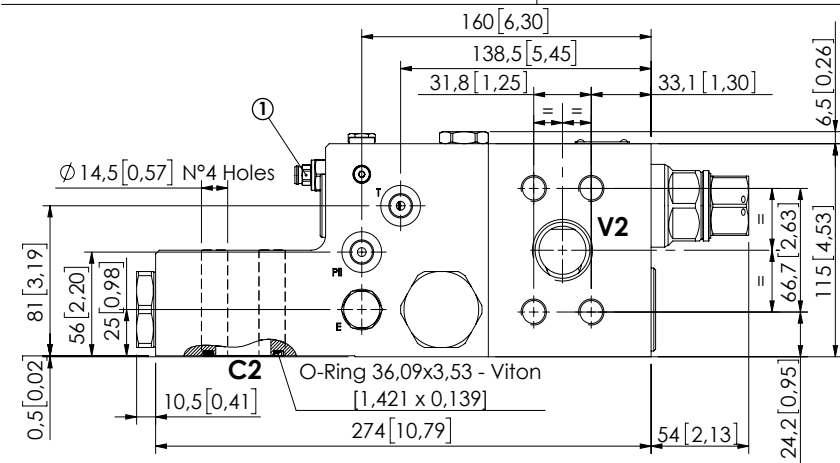

SPECIFICATIONS

Max. operating pressure:	420 bar (6000 psi)
Rated flow:	700 l/min (185 gpm)
Manifold:	Steel
Weight:	27,53 kg (60,69 lbs)
Contamination class to ISO 4406:	See technical spec.
MTF _d :	150 - 1200 years: See technical spec.

NOTES

When correctly adjusted for the specific excavator installation, these valves meet the requirement of ISO 8643.
For other configurations/quick codes not available in this catalogue page please consult factory

CURVES

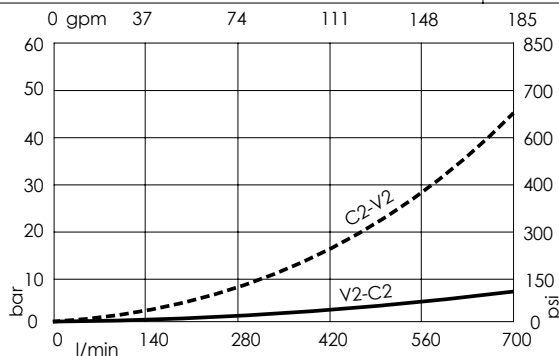

ORDERING CODES

Quick code	Description	Main ports size	Standard setting	Adjustment range	Pressure increase
ML000211	MLLT-700-AAGN-00-S11-N420	V2,C2:1" 1/4 SAE 6000 E,Pil,T:G 1/4"	① 400 bar @5 l/min(5800 psi @1,3 gpm) ② 10.5 bar (150 psi) Crack. pr. ③ 7.5 bar (100 psi) Crack. pr.	① 150-420 bar (2100-6000 psi) ② ③ 3-15 bar (50-200 psi)	① 236 bar/turn (3400 psi/turn) ② ③ 3,4 bar/turn (50 psi/turn)

CHECK AND METERING VALVE

MLLT-700-AAGN

FLANGED TYPE
1" 1/2 SAE 6000

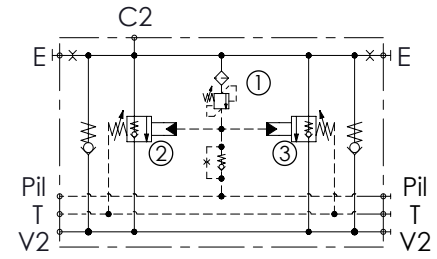
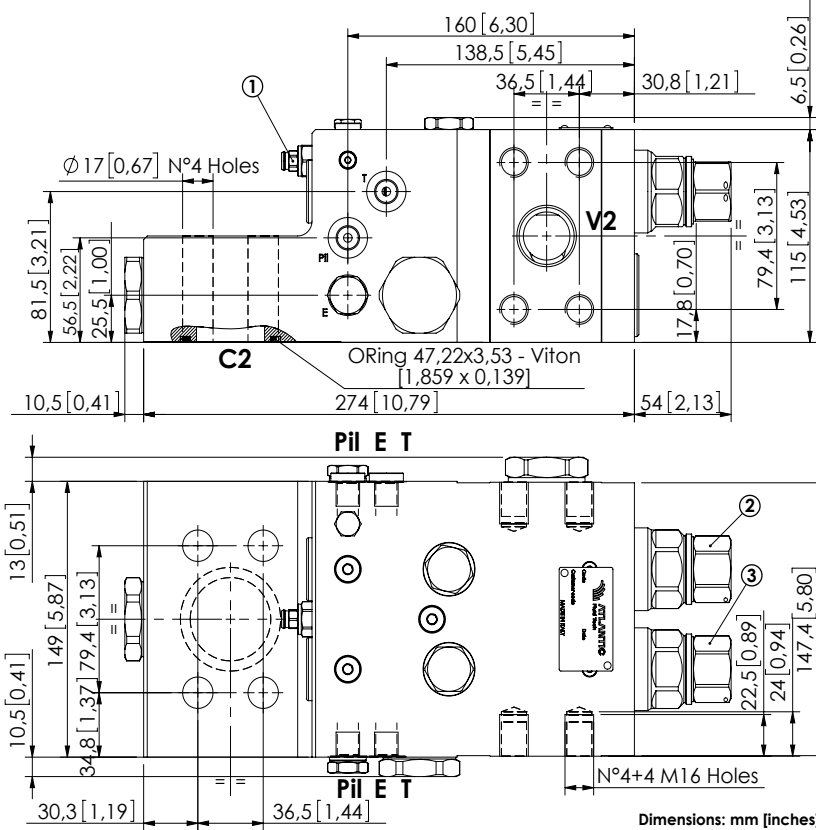

SPECIFICATIONS

Max. operating pressure:	420 bar (6000 psi)
Rated flow:	700 l/min (185 gpm)
Manifold:	Steel
Weight:	27.27 kg(60,19 lbs)
Contamination class to ISO 4406:	See technical spec.
MTTFd:	150 - 1200 years: See technical spec.

NOTES

When correctly adjusted for the specific excavator installation, these valves meet the requirement of ISO 8643.
For other configurations/quick codes not available in this catalogue page please consult factory

CURVES

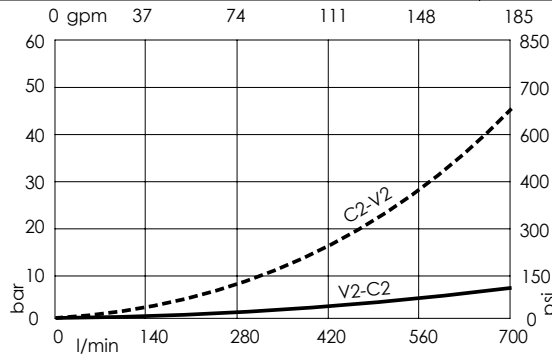

ORDERING CODES

Quick code	Description	Main ports size	Standard setting	Adjustment range	Pressure increase
ML000098	MLLT-700-AAGN-00-S22-N420	V2,C2:1" 1/2 SAE 6000 E,Pil,T:G 1/4"	① 400 bar @5 l/min(5800 psi @1.3 gpm) ② 10.5 bar (150 psi) Crack. pr. ③ 7.5 bar (100 psi) Crack. pr.	① 150-420 bar (2100-6000 psi) ② ③ 3-15 bar (50-200 psi)	① 236 bar/turn (3400 psi/turn) ② ③ 3,4 bar/turn (50 psi/turn)
ML000094	MLLT-700-AAJN-00-S22-N420	V2,C2:1" 1/2 SAE 6000 E,Pil,T:1/4" JIS	① 400 bar @5 l/min(5800 psi @1.3 gpm) ② 10.5 bar (150 psi) Crack. pr. ③ 7.5 bar (100 psi) Crack. pr.	① 150-420 bar (2100-6000 psi) ② ③ 3-15 bar (50-200 psi)	① 236 bar/turn (3400 psi/turn) ② ③ 3,4 bar/turn (50 psi/turn)

CHECK AND METERING VALVE

MLL-1400-AAGN

FLANGED TYPE
1" 1/2 SAE 6000

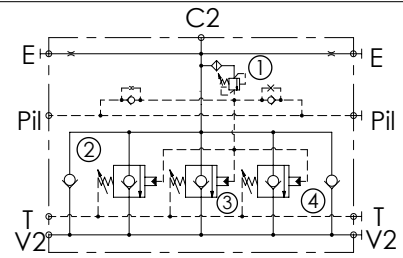
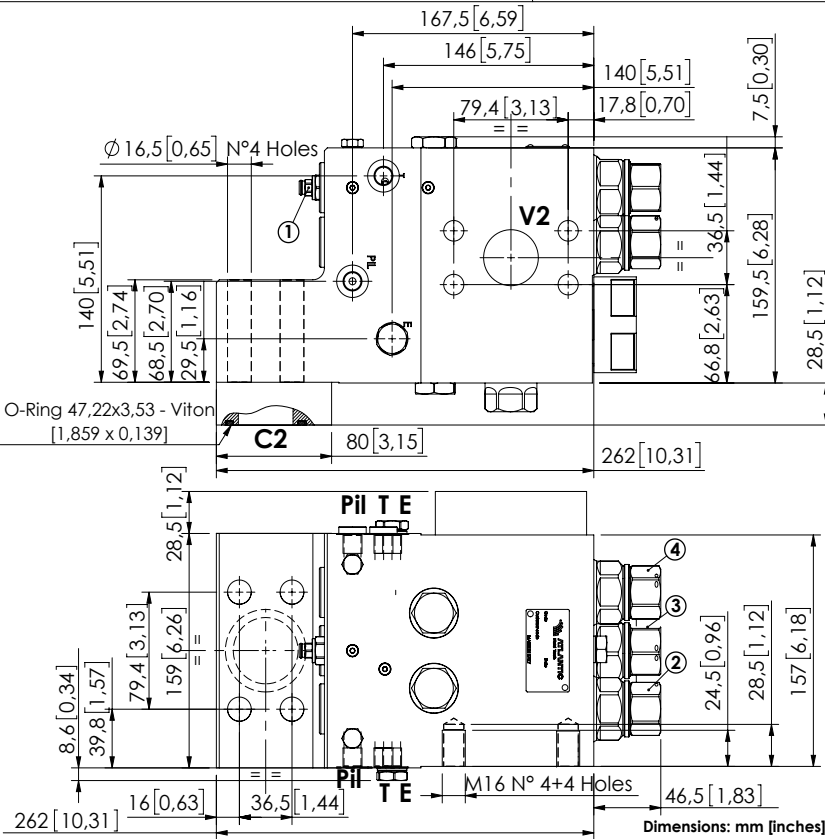

SPECIFICATIONS

Max. operating pressure:	420 bar (6000 psi)
Rated flow:	1400 l/min (370 gpm)
Manifold:	Steel
Weight:	43.12 kg (94.91 lbs)
Contamination class to ISO 4406:	See technical spec.
MTF _a :	150 - 1200 years: See technical spec.

NOTES

When correctly adjusted for the specific excavator installation, these valves meet the requirement of ISO 8643.
For other configurations/quick codes not available in this catalogue page please consult factory

CURVES

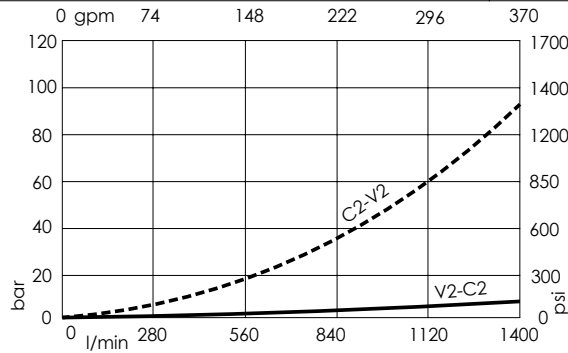

ORDERING CODES

Quick code	Description	Main ports size	Standard setting	Adjustment range	Pressure increase
ML000162	MLLT-1400-AAGN-00-S22-N420	V2,C2:1" 1/2 SAE 6000 E,Pil,T:G 1/4"	① 400 bar @5 l/min (5800 psi @1.3 gpm) ③ 7.5 bar Crack. pr. (100 psi) ②④ 8.5 bar Crack.pr. (120 psi)	① 150-420 bar (2100-6000 psi) ②③④ 3-15 bar (50-200 psi)	① 236 bar/turn (3400 psi/turn) ②③④ 3,4 bar/turn (50 psi/turn)

CHECK AND METERING VALVE



MLLT-1400-AAGR

FLANGED TYPE
2" SAE 6000
RIGHT VERSION

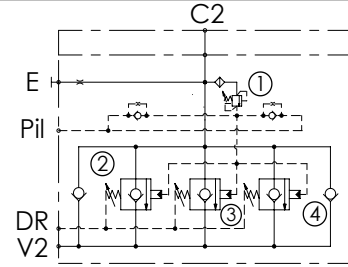
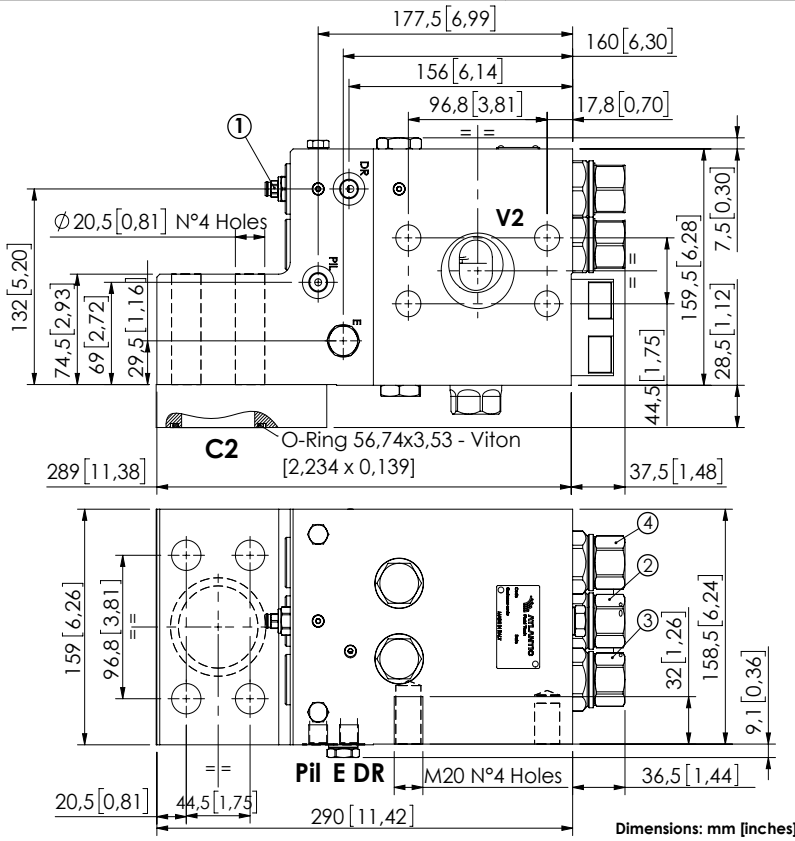

SPECIFICATIONS

Max. operating pressure:	420 bar (6000 psi)
Rated flow:	1400 l/min (370 gpm)
Manifold:	Steel
Weight:	45.75 kg (100,93 lbs)
Contamination class to ISO 4406:	See technical spec.
MTF _d :	150 - 1200 years: See technical spec.

NOTES

When correctly adjusted for the specific excavator installation, these valves meet the requirement of ISO 8643.
For other configurations/quick codes not available in this catalogue page please consult factory

CURVES

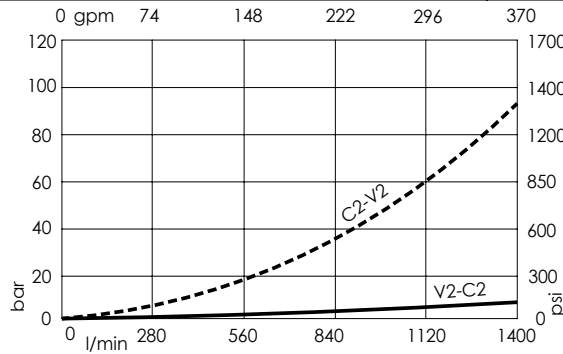

ORDERING CODES

Quick code	Description	Main ports size	Standard setting	Adjustment range	Pressure increase
ML000167	MLLT-1400-AAGR-00-S20-N420	V2,C2: 2" SAE 6000 E,Pil,DR: G 1/4"	① 400 bar @5 l/min (5800 psi @1,3 gpm) ② 7.5 bar Crack. pr. (100 psi) ③④ 8.5 bar Crack.pr. (120 psi)	① 150-420 bar (2100-6000 psi) ②③④ 3-15 bar (50-200 psi)	① 236 bar/turn (3400 psi/turn) ②③④ 3,4 bar/turn (50 psi/turn)

CHECK AND METERING VALVE

MLLT-1400-AAGL

FLANGED TYPE
2" SAE 6000
LEFT VERSION

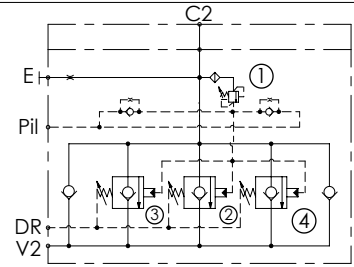
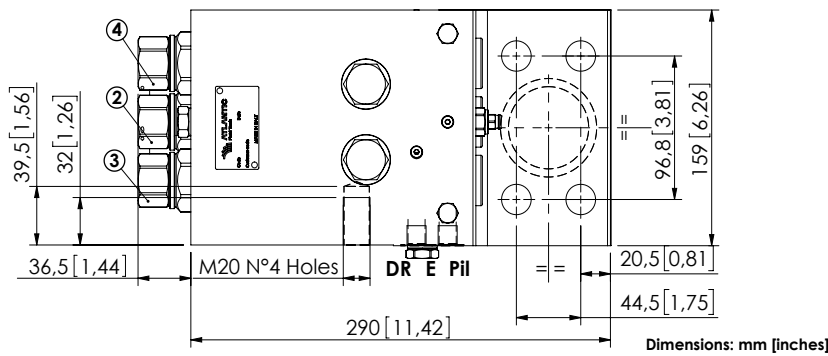
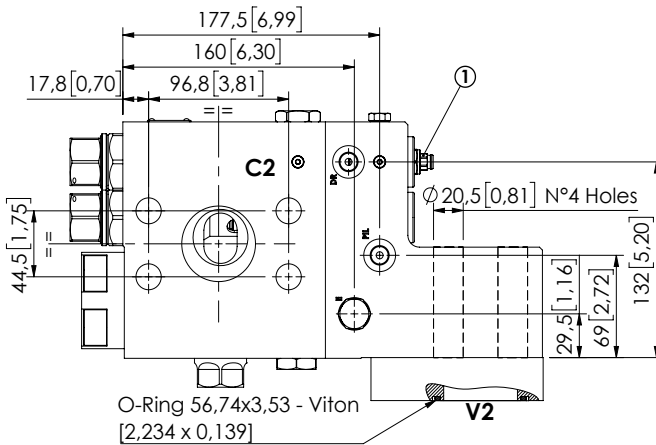

SPECIFICATIONS

Max. operating pressure:	420 bar (6000 psi)
Rated flow:	1400 l/min (370 gpm)
Manifold:	Steel
Weight:	45.77 kg (100,97 lbs)
Contamination class to ISO 4406:	See technical spec.
MTTF _a :	150 - 1200 years: See technical spec.

NOTES

When correctly adjusted for the specific excavator installation, these valves meet the requirement of ISO 8643.
For other configurations/quick codes not available in this catalogue page please consult factory

CURVES

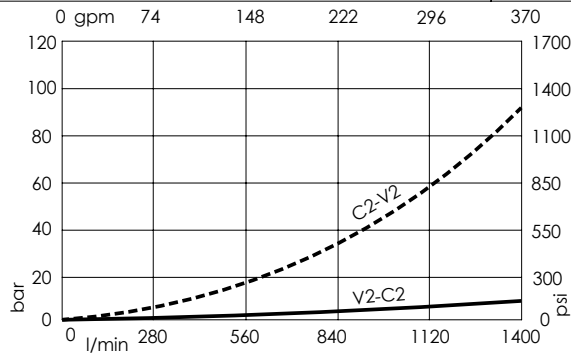

ORDERING CODES

Quick code	Description	Main ports size	Standard setting	Adjustment range	Pressure increase
ML000166	MLLT-1400-AAGL-00-S20-N420	V2,C2:2" SAE 6000 E,Pil,T:G 1/4"	① 400 bar @5 l/min (5700 psi @1,3 gpm) ② 7.5 bar Crack. pr. (100 psi) ③ ④ 8.5 bar Crack.pr. (120 psi)	① 150-420 bar (5000-6000 psi) ② ③ ④ 3-15 bar (50-200 psi)	① 236 bar/turn (3400 psi/turn) ② ③ ④ 3,4 bar/turn (50 psi/turn)

CHECK AND METERING VALVE

MLLT-1500-AAGR

FLANGED TYPE
3" SAE 3000 / 2" SAE 6000
RIGHT VERSION

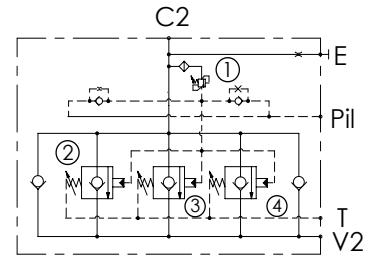
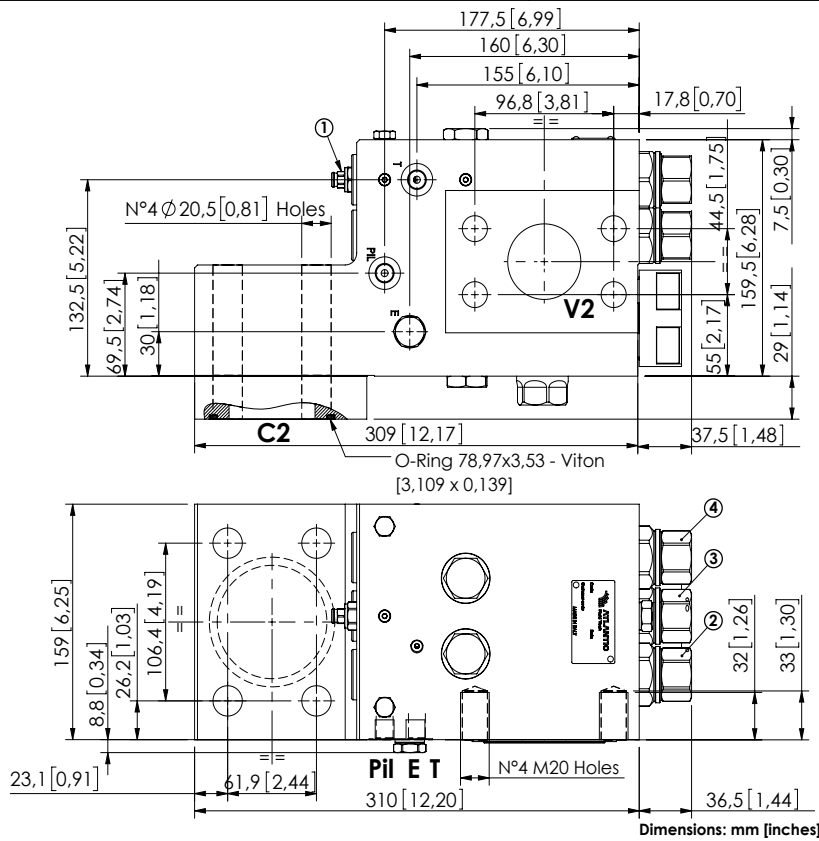

SPECIFICATIONS

Max. operating pressure:	420 bar (6000 psi)
Rated flow:	1500 l/min (396 gpm)
Manifold:	Steel
Weight:	47.14 kg (103,9 lbs)
Contamination class to ISO 4406:	See technical spec.
MTTFd:	150 - 1200 years: See technical spec.

NOTES

When correctly adjusted for the specific excavator installation, these valves meet the requirement of ISO 8643.
For other configurations/quick codes not available in this catalogue page please consult factory

CURVES

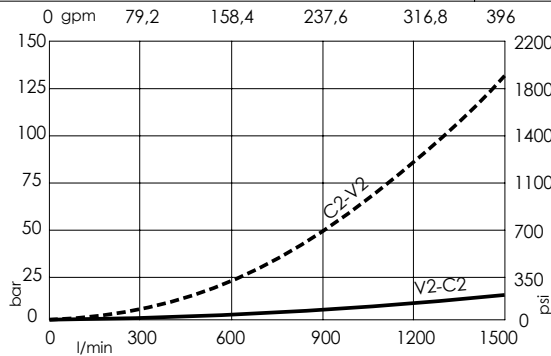

ORDERING CODES

Quick code	Description	Main ports size	Standard setting	Adjustment range	Pressure increase
ML000164	MLLT-1500-AAGR-00-S30-N420	V2:2" SAE 6000 C2:3" SAE 3000 E,Pil,T:G 1/4"	① 400 bar @5 l/min (5800 psi @1.3 gpm) ② ④ 8.5 bar Crack. pr. (120 psi) ③ 7.5 bar Crack.pr. (100 psi)	① 150-420 bar (2100-6000 psi) ②③④ 3-15 bar (50-200 psi)	① 236 bar/turn (3400 psi/turn) ②③④ 3,4 bar/turn (50 psi/turn)

CHECK AND METERING VALVE

MLLT-1500-AAGL

FLANGED TYPE
3" SAE 3000 / 2" SAE 6000
LEFT VERSION

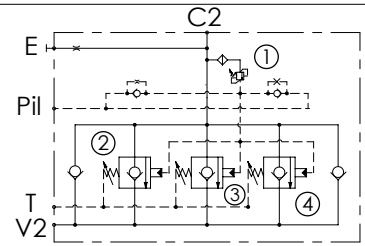
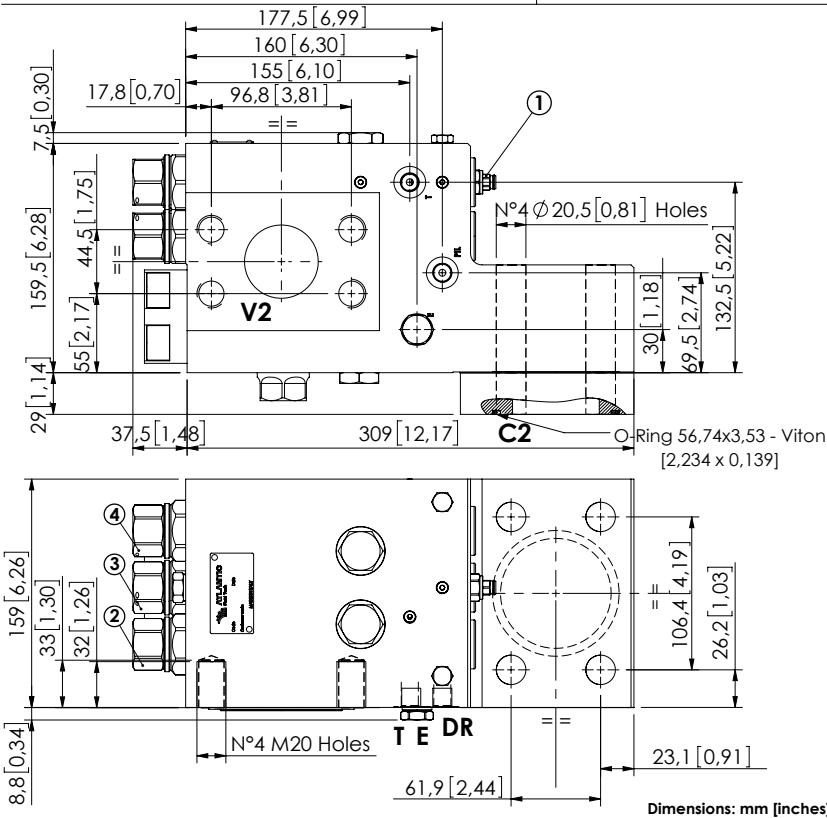

SPECIFICATIONS

Max. operating pressure:	420 bar (6000 psi)
Rated flow:	1500 l/min (396 gpm)
Manifold:	Steel
Weight:	47.13 kg (103.9 lbs)
Contamination class to ISO 4406:	See technical spec.
MTFa:	150 - 1200 years: See technical spec.

NOTES

When correctly adjusted for the specific excavator installation, these valves meet the requirement of ISO 8643.
For other configurations/quick codes not available in this catalogue page please consult factory

CURVES

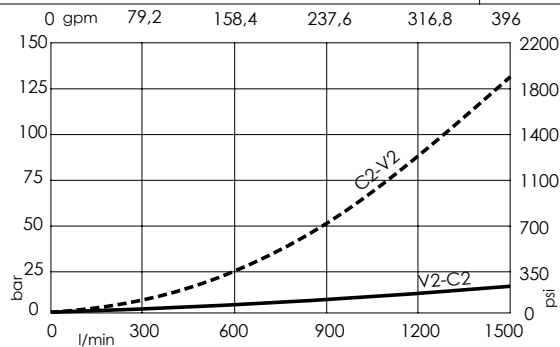

ORDERING CODES

Quick code	Description	Main ports size	Standard setting	Adjustment range	Pressure increase
ML000163	MLLT-1500-AAGL-00-S30-N420	V2: 2" SAE 6000 C2: 3" SAE 3000 E, Pil, T: G 1/4"	① 400 bar @5 l/min (5800 psi @1.3 gpm) ②④ 8.5 bar Crack. pr. (120 psi) ③ 7.5 bar Crack.pr. (100 psi)	① 200-420 bar (2800-6000 psi) ②③④ 3-15 bar (50-200 psi)	① 236 bar/turn (3400 psi/turn) ②③④ 3,4 bar/turn (50 psi/turn)

CHECK AND METERING VALVE

MLNT-250-AAGN

FLANGED TYPE
3/4" SAE 6000

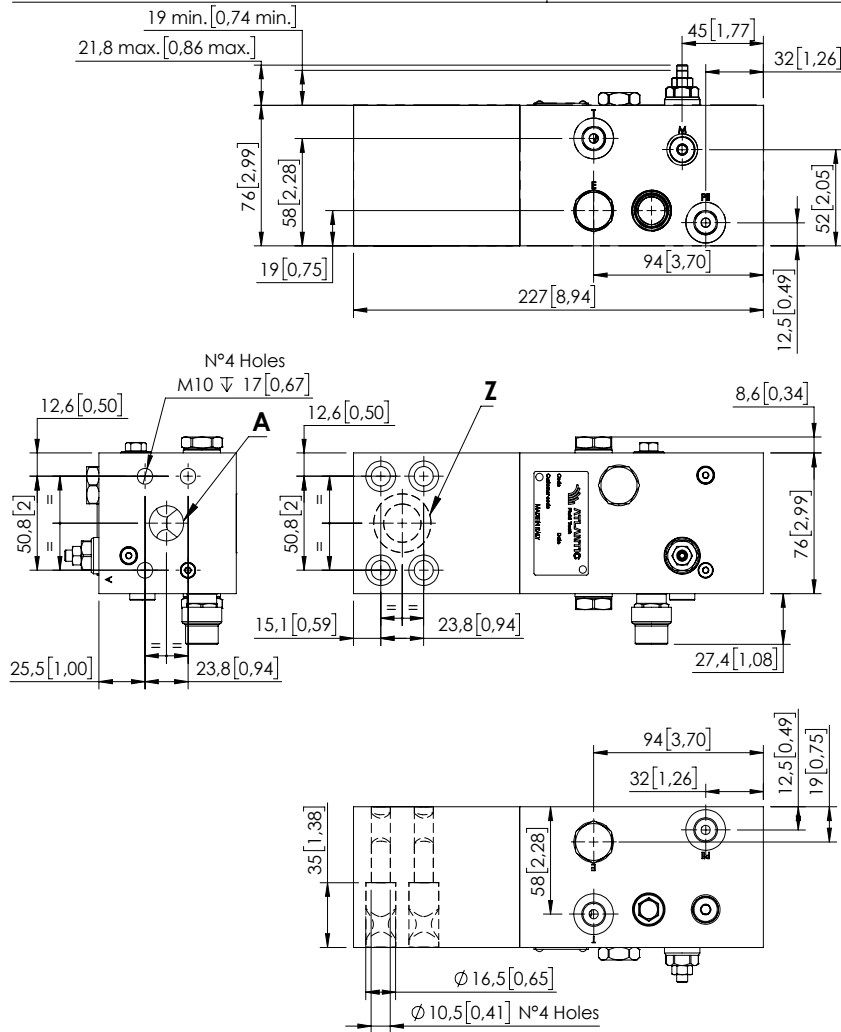

Dimensions: mm [inches]

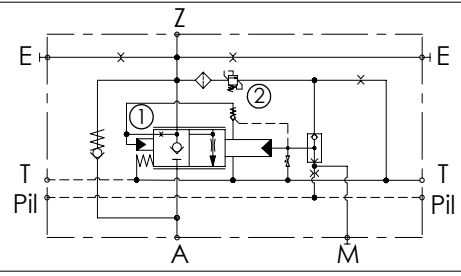

SPECIFICATIONS

Max. operating pressure:	420 bar (6000 psi)
Rated flow:	250 l/min (66 gpm)
Manifold:	Steel
Weight:	8,54 kg (18,32 lbs)
Contamination class to ISO 4406:	See technical spec.
MTF _d :	150 - 1200 years: See technical spec.

NOTES

When correctly adjusted for the specific excavator installation, these valves meet the requirement of ISO 8643.
For other configurations/quick codes not available in this catalogue page please consult factory

CURVES

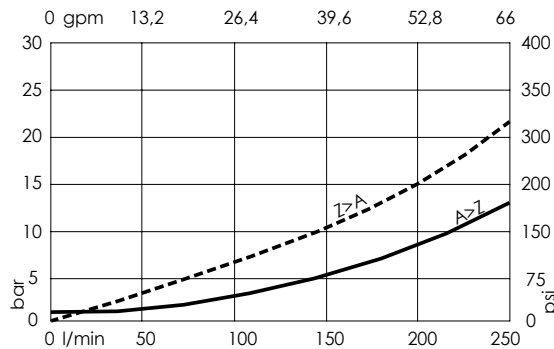

ORDERING CODES

Quick code	Description	Main ports size	Standard setting	Adjustment range	Pressure increase
ML000900	MLNT-250-AAGN-00-S34-N420	Z,A: 3/4" SAE 6000 E,T,Pil: G1/4" M: G1/8"	① 5,5 bar Cracking press. (75 psi Cracking press.) ② 420 bar @5 l/min (6000 psi @1,3 gpm)	① 3-10 bar (50-150 psi) ② 200-420 bar (2900-6000 psi)	① 1,8 bar/turn (25 psi/turn) ② 236 bar/turn (3400 psi/turn)

Revision D

CHECK AND METERING VALVE

MLNT-350-AAGN

FLANGED TYPE
1" SAE 6000

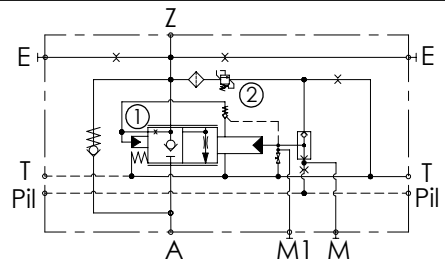
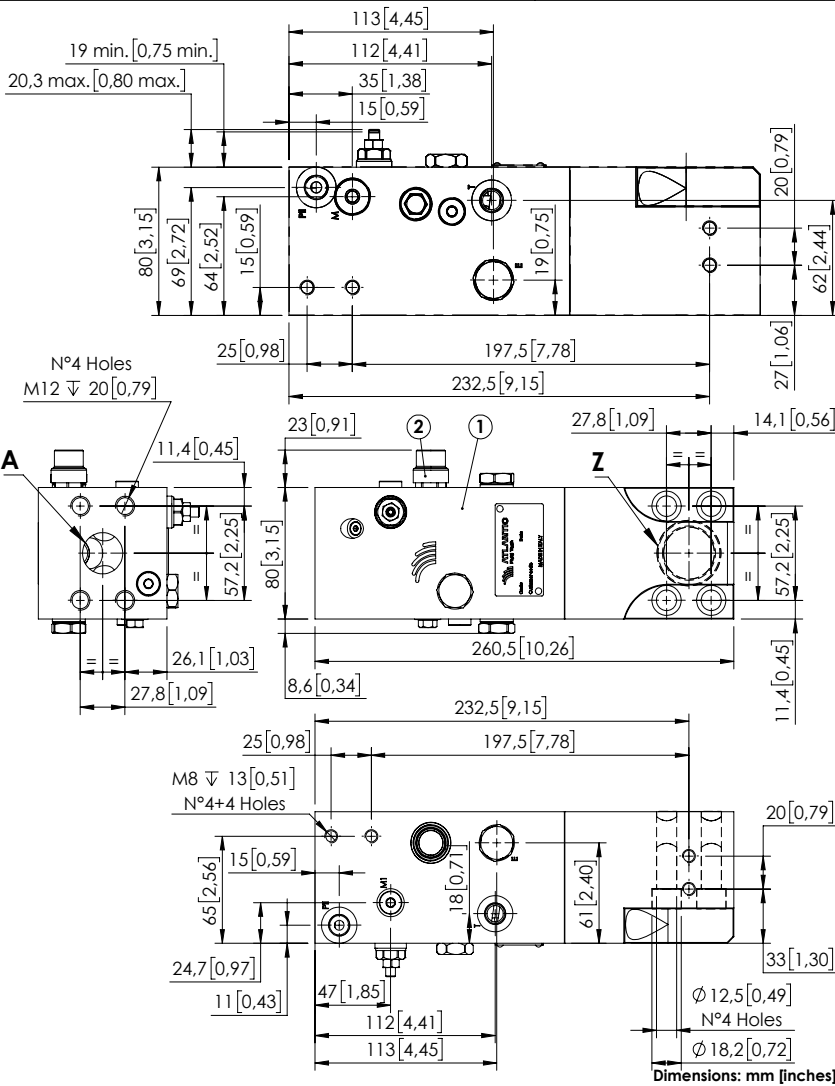

SPECIFICATIONS

Max. operating pressure:	420 bar (6000 psi)
Rated flow:	350 l/min (92 gpm)
Manifold:	Steel
Weight:	10.18 kg (22.47 lbs)
Contamination class to ISO 4406:	See technical spec.
MTF _d :	150 - 1200 years: See technical spec.

NOTES

When correctly adjusted for the specific excavator installation, these valves meet the requirement of ISO 8643.
For other configurations/quick codes not available in this catalogue page please consult factory

CURVES

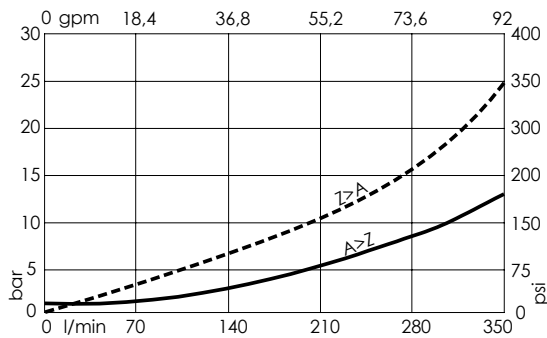

ORDERING CODES

Quick code	Description	Main ports size	Standard setting	Adjustment range	Pressure increase
ML000271	MLNT-350-SAGN-00-S10-V420	Z, A: 1" SAE 6000 E, T, Pii, M: G1/4" M1: G1/8"	① 5.5 bar Cracking press. (75 psi Cracking press.) ② 420 bar @5 l/min (6000 psi @1,3 gpm)	① 3-17 bar (50-250 psi) ② 200-420 bar (2900-6000 psi)	① 2.4 bar/turn (35 psi/turn) ② 236 bar/turn (3400 psi/turn)

Revision F

CHECK AND METERING VALVE

MLNT-500-AAGN

FLANGED TYPE
1" - 1/4 SAE 6000

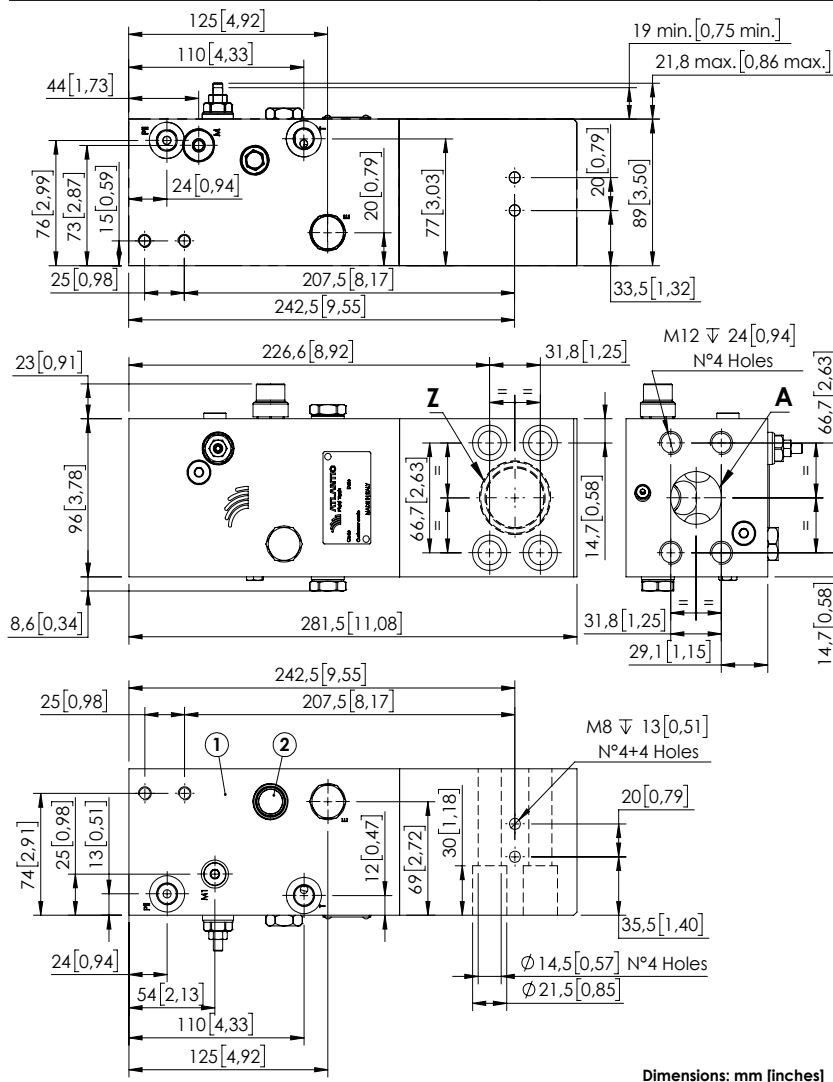

Dimensions: mm [inches]

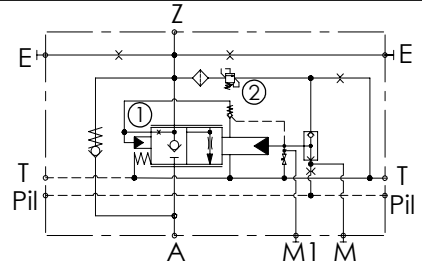

SPECIFICATIONS

Max. operating pressure:	420 bar (6000 psi)
Rated flow:	500 l/min (132 gpm)
Manifold:	Steel
Weight:	14.92 kg (32,87 lbs)
Contamination class to ISO 4406:	See technical spec.
MTTF _d :	150 - 1200 years: See technical spec.

NOTES

When correctly adjusted for the specific excavator installation, these valves meet the requirement of ISO 8643.
For other configurations/quick codes not available in this catalogue page please consult factory

CURVES

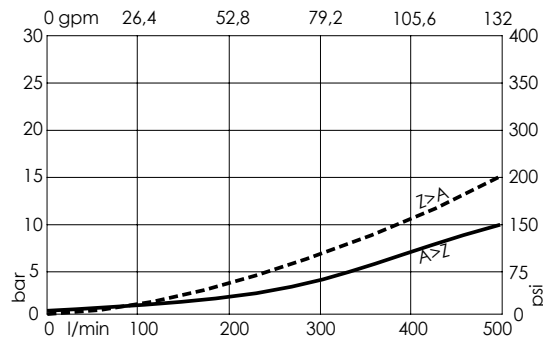

ORDERING CODES

Quick code	Description	Main ports size	Standard setting	Adjustment range	Pressure increase
ML000333	MLNT-500-SAGN-00-S11-N420	Z,A: 1"-1/4 SAE 6000 E,T,Pil,M: G1/4" M1: G1/8"	① 5,5 bar Cracking press. (75 psi Cracking press.) ② 420 bar @5 l/min (6000 psi @1,3 gpm)	① 2-10 bar (25-150 psi) ② 200-420 bar (2900-6000 psi)	① 2 bar/turn (25 psi/turn) ② 236 bar/turn (3400 psi/turn)

Revision C